



Integrated Project - EUWB

Contract No 215669

Deliverable

D4.5.1

Analysis of location awareness in wireless/cellular networks

Contractual date:	M15
Actual date:	M17
Authors:	Juan Chóliz (UZ), Ángela Hernández (UZ), Carlos Héraclés Morais de Lima (CWC), Pedro Henrique Juliano Nardelli (CWC), Shangbo Wang (UDE), Dong Xu (UDE)
Participants:	UOZ, CWC, UDE
Work package:	WP4
Security:	PU
Nature:	Report
Version:	1.0
Total number of pages:	61

Abstract

Wireless networks capacity and efficiency can be improved through the design and development of enhanced location-aware strategies and algorithms. Concerning cellular access networks, radio resource management algorithms can potentially be enhanced through the use of location information, with resource allocation and mobility management as the most interesting applications. Concerning wireless ad-hoc networks, the knowledge of the location of the nodes can be exploited in multiple access and network routing in order to improve the capacity and performance of multi-hop networks.

Keywords

Location-awareness, UWB, cellular, RRM, handover, adaptive, predictive, resource allocation, capacity, ad-hoc, multi-hop, efficiency

Table of Contents

1	Executive summary	8
2	Location-Aware Radio Resource Management in Cellular Networks	9
2.1	Introduction	9
2.2	Handover management and admission control.....	10
2.2.1	Handover strategies	10
2.2.2	Admission control	12
2.2.3	Examples in literature.....	13
2.3	Predictive resource reservation for mobility management	14
2.3.1	Classic approaches	15
2.3.2	Predictive Channel Reservation	16
2.3.3	Examples in literature.....	18
2.4	Load control and balance in cellular based networks.....	25
2.4.1	Load control and balance.....	25
2.4.2	Examples in literature.....	26
2.5	Adaptive resource allocation for Intersystem-handover.....	27
2.5.1	Overview	27
2.5.2	Location-aware algorithm in UMTS network	27
2.5.3	Adaptive resource allocation algorithm.....	27
2.5.3.1	UMTS to GSM IS-HO	27
2.5.3.2	GSM to UMTS IS-HO	28
2.5.4	Simulation	28
2.5.4.1	Mobility model	28
2.5.4.2	Simulation results	30
2.6	Resource allocation and interference coordination in OFDMA-based networks.....	31
2.6.1	Classic approaches	32
2.6.2	Interference coordination in an OFDMA system	36
2.6.3	Advantages of interference coordination.....	38
2.6.4	Use of location information.....	40
2.6.5	State of art and examples in literature	40
3	Location-Awareness in Wireless Ad-Hoc Networks.....	45
3.1	Impact of location information on the network capacity.....	45
3.1.1	Multi-hop Aggregate Information Efficiency.....	45

3.1.2	Network modelling.....	46
3.1.3	Distance characterization.....	46
3.1.4	Active links.....	47
3.1.5	Outage probability.....	47
3.1.6	Multi-hop parameters.....	48
3.1.7	Preliminary results.....	48
3.2	Position-centric Strategies for Autonomous Multi-Hop Networks.....	49
3.2.1	Preliminary Evaluation.....	50
3.2.2	System model.....	50
3.2.3	Preliminary Results.....	53
3.3	Final Remarks and Perspectives.....	55
4	Conclusions.....	56
	References.....	58
	Acknowledgement.....	61

List of Figures

Figure 2-1: Threshold Distance (TD) concept [6].....	17
Figure 2-2: Reservation Distance concept [8].....	17
Figure 2-3: Cluster of the seven cells. Red arrows represent handover between two cells.....	28
Figure 2-4: Blocking probabilities. $\bar{T} = 100$, $C=5$, $v_0 = 50$	31
Figure 2-5: Cell-border interference users in the uplink [38].....	32
Figure 2-6: Frequency reuse scheme at cell level with FRF=3 [39]	33
Figure 2-7: Co-channel interference on MS for FRF=1 (blue lines) and FRF=3 (red lines) [25].....	34
Figure 2-8: FFR scheme at cell level [32].....	34
Figure 2-9: FFR schemes at sector level	35
Figure 2-10: Frequency resources allocation for a soft-FFR scheme [22]	35
Figure 2-11: Frequency resources allocation for a hard-FFR scheme [22].....	36
Figure 2-12: Partition of OFDM spectrum in R disjunct subsets F_n [38]	37
Figure 2-13: Frequency planning in an interference coordination scheme	37
Figure 2-14: Frequency pattern allocation for a terminal approaching cell-border [38].....	38
Figure 2-15: Distribution of interference power over the F_n frequency pattern subsets [38]	39
Figure 2-16: Subchannel allocation scheme in a UFR system at cell level [39]	42
Figure 2-17: Subchannel allocation scheme in a modified UFR system with position information [39]	43
Figure 3-1: Multi-hop aggregate information efficiency vs. transmission range for different hopping strategies, and with $p_t + p_r = 0.02$, $\alpha = 4$, and $\epsilon = 4$ bits/sec-Hz.....	49
Figure 3-2: Sectoral decision region.	51
Figure 3-3: Convex lens decision regions.	52
Figure 3-4: Illustration of routing trajectories when simulating a single source node.	53
Figure 3-5: Illustration of routing trajectories when simulating multiple source nodes.....	53
Figure 3-6: Packet delivery success ratio for the contention-based geographic forwarding strategies.	54
Figure 3-7: Hop-excess distributions for the contention-based geographic forwarding schemes.....	55

Abbreviations

3GPP	3rd Generation Partnership Project
ACR	Adaptive Channel Reservation
BAP	Blocked Access Protocol
BCA	Borrowing Channel Assignment
BS	Base Station
BSC	Basestation Switching Center
CDMA	Code Division Multiple Access
CDPD	Cellular Digital Packet Data
CN	Core Network
CQI	Channel Quality Indicator
CRA	Contention Resolution Algorithm
CRI	Contention Resolution Interval
CSMA	Carrier Sense Multiple Access
CTS	Clear To Send
DCA	Dynamic Channel Allocation
E-UTRA	Evolved UMTS Terrestrial Radio Access
EUWB	CoExisting Short Range Radio by Advanced Ultra-WideBand Radio Technology
FCA	Fixed Channel Allocation
FCC	Federal Communications Commission
FDMA	Frequency Division Multiple Access
FFR	Fractional Frequency Reuse
FRF	Frequency Reuse Factor
FUSC	Full Usage of SubChannels
GC	Guarded Channel
GPS	Global Positioning System
GSM	Global System for Mobile communications
HCA	Hybrid Channel Allocation
ICI	Inter-Cell Interference
IEEE	Institute of Electrical and Electronics Engineers
IS-HO	Intersystem-handover
LSC	Location Service

LT	Location Tracking
LTE	Long Term Evolution
MAC	Medium Access Control
MS	Mobile Station
OFDMA	Orthogonal Frequency Division Multiple Access
OOP	Object Oriented Programming
OTDOA	Observed Time Difference Of Arrival
PCR	Predictive Channel Reservation
PUSC	Partial Usage of SubChannels
QoS	Quality of Service
RAT	Radio Access Technology
CDP	Call Dropping Probability
CBP	Call Blocking Probability
RMA	Random Multiple Access
RNC	Radio Network Controller
RPSS	Received Pilot Signal Strength
RRM	Radio Resource Management
RSA	Relay Selection Algorithm
RSS	Received Signal Strength
RTD	Real Time Difference
RTS	Request To Send
SIR	Signal to Interference Ratio
TD	Threshold Distance
TDD	Time Division Duplex
TDMA	Time Division Multiple Access
TDOA	Time Difference Of Arrival
TOA	Time Of Arrival
UE	User Equipment
UMTS	Universal Mobile Telecommunications System
UWB	Ultra-WideBand
WCDMA	Wideband Code Division Multiple Access
WiMAX	Worldwide Interoperability for Microwave Access

1 Executive summary

Task 4.5 “Study of new system concepts with location awareness” deals with the use of location information in wireless/cellular networks. Besides its use for providing users with location information or developing novel location-aware applications and services, location-awareness can also be applied within the wireless networks themselves for the design and development of enhanced strategies and algorithms in order to improve network capacity and efficiency. New concepts and enhanced radio resource management algorithms are expected to be proposed within this Task. In this deliverable, the potential applications of location awareness in wireless networks are analysed, including both cellular access networks and wireless ad-hoc networks. Within all the possible applications of location awareness, the efforts will focus on a few particularly interesting applications that will be subject of extensive research in the following period. These applications are presented in detail and early results are presented in some cases.

In chapter 2, the possible applications of location-awareness in cellular networks are explored. Several radio resource management procedures that could potentially be enhanced are presented, such as handover management, admission control, load control, resource allocation... Potential benefits of the use of location information are analysed and related works that can be found in the literature are summarized.

Two particular applications have been selected to be subject of further investigation and are here presented in detail. On the one hand, Inter-system handover in cellular networks is investigated. It major refers to the handover between two RATs (Radio Access Technologies). Handover has important influences on system parameters, such as CBP (Call Blocking Probability) and CDP (Call Dropping Probability). Handover requires the allocation of channels in the target cell, which may lead to blocking in the target cell if there are not enough resources for the new calls. Inadequate resource allocation mechanism for Inter-system handover may lead to the dropping of current call. Section **Fehler! Verweisquelle konnte nicht gefunden werden.** proposes adaptive resource allocation mechanisms. The location information of the UE (User Equipment) is utilized as additional condition to decide whether an Inter-system handover shall be performed.

On the other hand, OFDM modulation is being widely adopted in up-to-date radio interfaces such as WiMAX Mobile and LTE E-UTRA and frequency reuse of 1 is desired in order to maximize system's efficiency, but this entails high inter-cell interference and degradation for cell-border users. In order to avoid cell-border degradation with a minimum loss of efficiency, different frequency planning and allocation solutions are being investigated. In this deliverable the main approaches and solutions proposed within the IEEE 802.16 and 3GPP LTE standardization processes are summarized and a dynamic interference coordination scheme with location awareness is proposed.

The impact of location awareness on the overall performance of infra structureless networks is addressed in chapter 3. A mathematical framework resorting to stochastic geometry is used to characterize the benefit of using location information. A novel metric coined *Multi-hop Aggregate Information Efficiency* (MIE_{h}) is introduced as a suitable figure of metric to characterize the network performance. Additionally, a system-level event-driven simulator is utilized to further assess the advantages and disadvantages of employing the knowledge of location information, either local or global, to augment the operation on medium access control strategies and network routing protocols.

2 Location-Aware Radio Resource Management in Cellular Networks

2.1 Introduction

Radio Resource Management (RRM) comprises different system-level strategies and algorithms aiming to use the limited radio spectrum resources and radio network infrastructure as efficiently as possible. RRM algorithms at the radio interface such as power control, interference management, admission control, resource reservation for mobility management, load control, channel allocation..., determine how the available radio resources of the system must be used and shared among the different users in an efficient way. In all the cases, the objective is to maximize the system spectral efficiency, while quality of service and grade of service requirements should be above a certain level.

The availability of positioning information in user stations can be exploited to design more advanced implementations of these Radio Resource Management strategies, thus increasing the efficiency of the cellular access networks (UMTS, IEEE 802.16...). In order to design even more efficient algorithms, location information can be combined with information of the environment topology (e.g. road network for tracking vehicles, presence of buildings or obstacles, etc.) and with statistic information (e.g. probability of different paths).

The increasing popularity of GPS (Global Positioning System) and the E-911 ruling issued by Federal Communications Commission (FCC), requiring the accurate localization of mobile callers requesting emergency services via 911 by the operators of mobile communication networks, motivated the integration of localization systems within mobile cellular networks. This encouraged both the research and development of location systems based on the information already available on the cellular networks (based on received power or time of arrival estimations between the mobile terminals and the base stations) and the research on the possible use of the location information on Radio Resource Management. Some proposals can be found in the literature since one decade, although research on the development of location-aware RRM algorithms for more efficient operation of wireless networks has gained an increasing interest with new and most sophisticated applications. Some examples of RRM procedures that are suitable to be enhanced are:

- Handover management and admission control: In general, the decision to perform a handover is made on the basis of received signal strength or link quality information. The use of positioning information allows a more accurate selection of the crossover point (avoiding the ping-pong effect and reducing the dropping probability) and a better selection of the destination base station (reducing the number of handovers needed), resulting in an increase of the throughput and a reduction of the signalling load.
- Resource reservation for mobility management: Provision of QoS in the connection level focuses on developing strategies to minimize the forced termination of handoff calls and the risk of unnecessary block of new calls. In general, adaptive reserve of resources for handoff connections, based on the estimated position, movement and the desired QoS for each class of traffic associated to mobiles stations are desirable. Reservation of resources and mobile's call arrival prediction are closely related. The knowledge of the position and trajectory of a mobile allows an earlier detection of the need of the handover and therefore the reservation of resources in advance, thus reducing the handover dropping probability. Within this topic, one

particular application that is going to be studied in detail is adaptive resource allocation for Intra-system handover, i.e. between UMTS and GSM.

- Load control and balance: Knowledge of the position and trajectory of a mobile can be used to predict both the arrival of calls in handover and the amount of time that a call is going to stay in the cell (dwell time). Furthermore, in case of congestion of one of the cells, knowledge of the position and trajectory of each mobile would be helpful in order to decide which mobiles are more likely to be reallocated and to which cells should be allocated, thus balancing traffic load among the neighbour cells.
- Resources allocation and interference management: Location-awareness can be used to design enhanced channel allocation protocols in TDMA, FDMA and CDMA systems, reducing the co-channel inference and increasing the bandwidth efficiency. For example, taking advance of fractional frequency reuse schemes, a set of channels can be reserved to be exclusively used by cell-border users, which are more likely to suffer degradation due to interference. On the cell-border channels a reuse factor higher than 1 (e.g. of 3) is applied, while the rest of the channels can be used with a reuse factor of 1 by all the cell-centre users, as they are not so sensitive to interference.

2.2 Handover management and admission control

This section deals with the possible applications of positioning information in the handover procedure. Apart from the possibility of estimating the trajectory of the mobiles, thus enabling the reservation of resources in the cells along the expected trajectory of the mobile in advance, which will be presented in detail in Section 3.3, this section will focus on the possible use of location information in the handover decision algorithm.

In general, handover decision is made based on received signal strength or link quality information. The use of positioning information allows a more accurate selection of the crossover point (avoiding the ping-pong effect and reducing the dropping probability) and a better selection of the destination base station (reducing the number of handovers needed), resulting in an increase of the throughput and a reduction of the signalling load.

2.2.1 Handover strategies

As an essential functionality of the mobile networks, handover mechanism guarantees the user mobility in a mobile network wherein the subscriber can move around, keeping alive its connection to the network. When the mobile moves from the coverage area of one cell (source cell) to another (target cell), a new connection to the target cell has to be set up and the connection with the old cell has to be released. Regardless of being necessary, all types of handovers have a common drawback; they decrease the overall system performance due to the signalling load caused by rerouting the ongoing connection to the new cells to where mobile is entering. As a central component of Radio Resource Management (RRM), Handover Control (HC) is responsible for managing the ongoing calls even when mobile stations cross the border from one cell into another.

A handover can take place between different cells (inter-cell handover) or within a cell (intra-cell handover), for example to allocate a new channel in case of degradation of the current channel due to interference or fading. Also a handover can take place between cells of different scope. For example, a

common strategy is to have a macrocell overlapping multiple microcells, so when a user is detected to be moving faster than a certain threshold, the call can be transferred to the macrocell in order to minimise the frequency of the handovers between the microcells. Finally, there are also vertical handovers where a call's connection is transferred from one access technology to another.

Handover can be classified between hard and soft. A hard handoff is one in which the channel in the source cell is released before the channel in the target cell is engaged. Thus the connection to the source is broken before the connection to the target is made. Hard handoffs are intended to be instantaneous in order to minimize the disruption to the call. On the other hand, a soft handoff is one in which the channel in the source cell is retained and used for a while in parallel with the channel in the target cell. In this case the connection to the target is established before the connection to the source is broken. When a call is in a state of soft handoff the signal of the best of all used channels can be utilized for the call at a given moment or all the signals can be combined to produce a clearer copy of the signal. The latter is more advantageous, and when such combining is performed both in the downlink and the uplink the handoff is termed as softer.

The main advantage of the soft handover over the hard handover is the higher reliability, as the connection to the source cell is broken only when a reliable connection to the target cell has been established and therefore the chances that the call will be terminated abnormally due to a failed handoff are lower. Furthermore, channels in multiple cells are maintained simultaneously and the call could only fail if all of the channels are interfered or fade at the same time. On the contrary, if a hard handover fails the call may be temporarily disrupted or even terminated abnormally. On the other hand, soft handover requires more complex hardware in the mobile terminals, which must be capable of processing several channels in parallel. Another drawback of soft handover is a higher need of resources, as a single call uses several channels, thus reducing the global capacity of the network.

Although soft handover is technically possible in any technology, the cost of implementing them for analog technologies is prohibitively high and none of the commercially successful in the past technologies (e.g. AMPS, TACS, NMT, etc.) had this feature. Implementation of soft handover in technologies based on FDMA also faces a high cost for the terminals (due to the need to have multiple parallel radio-frequency modules), while those based on TDMA or a combination of TDMA/FDMA, in principle, allow not so expensive implementation of soft handover. However, none of the 2G technologies based on TDMA and FDMA (e.g. GSM, D-AMPS, etc.) implement soft handover. Concerning 2G and 3G technologies based on CDMA, hardware for supporting soft handover is not so complex and on the other hand, it is necessary to avoid interference arising due to the so-called "near-far" effect. Therefore, most of CDMA based systems (e.g. UMTS, CDMA2000, etc.) implement soft handover.

For the practical realisation of handoffs in a cellular network each cell is assigned a list of potential target cells, which can be used for handing-off calls from this source cell to them. These potential target cells are called neighbours and the list is called neighbour list. During a call one or more parameters of the signal in the downlink and/or uplink are monitored and assessed in order to decide when a handoff may be necessary. The handover may be requested by the mobile or by the base station of its source cell. Once the need of a handover is determined, the phone and/or the base stations of the neighbouring cells monitor each other others' signals and the best target candidates are selected among the neighbouring cells. When the monitored parameters cross a certain threshold, the handover takes place. As it was previously commented, in CDMA systems a mobile in soft handover is connected to several cells simultaneously, which are referred to as the "active set", and it processes the

received signals in parallel using a rake receiver. Each signal is processed by a module called rake finger. A usual design of a rake receiver includes three or more rake fingers used for processing signals from as many cells and one additional finger used to search for signals from other cells. If the search finger finds a sufficiently-strong signal from a new cell this cell is added to the active set.

In analog systems the parameters used as criteria for requesting a handover are usually the received signal power and the received signal-to-noise ratio (the latter may be estimated by inserting additional tones). In non-CDMA 2G digital systems the criteria for requesting a handover may be based on estimates of the received signal power, bit error rate (BER) and block error/erasure rate (BLER) and/or distance between the mobile and the base station (estimated from the radio signal propagation delay). In CDMA systems, the most common criterion for requesting a handover is signal-to-interference ratio (E_c/I_o) measured in the pilot channel and/or Received Signal Code Power (RSCP).

Some authors propose the use of positioning information in the handover decision procedure, whether on exclusively location-based schemes or in hybrid schemes combining location information with received signal strength or link quality information. The main advantages provided by the use of positioning information in the handover procedure are:

- Reduced power consumption in the mobile terminals, as there is no need of monitoring the signal strength of several base stations
- Reduced signalling load, as the mobile terminal just has to report its own position (or nothing if the position is retrieved by the network itself) instead of several measurements performed with different base stations
- Possibility of using information concerning the mobile's estimated trajectory to select the target cell instead of choosing the cell with higher signal strength, thus reducing the number of handovers needed and the associated signalling load.
- Higher stability of the parameters used for handover decision, as the positioning information is less sensitive to fading or presence of obstacles (in case of GPS or TOA based localization), which entails a better selection of the target cell and the crossover point, thus reducing the ping-pong effect and the number of handovers.

2.2.2 Admission control

Admission control is the radio resource management procedure by which the network decides if a connection establishment request is accepted or not, according to the available resources and the characteristics of the traffic and QoS required by the requested connection. The objective of admission control is to make sure that the number of users admitted to the system allows guaranteeing the quality of service at call level and packet level. Furthermore, it must provide maximum efficiency avoiding the forced termination of calls in progress and blocking of new calls.

Location information of mobile terminals, and particularly their position and trajectory, can be very useful in order to determine which one is the optimum base station to establish a connection. For example, in case a terminal moving out of a cell requests a connection, knowledge of the trajectory of the mobile allows detecting this situation and allocating the resources for this connection in the cell the mobile is moving towards instead of the current cell, thus avoiding the handover.

Another example would be in case of having a macrocell overlapped to multiple microcells in order to serve the connections of high mobility users, thus minimizing the need of handovers. Knowledge of

user mobility characteristics prior to the connection establishment allows that a connection requested by a high mobility terminal is established directly in the macrocell, thus avoiding the handovers that would take place within the microcells before the decision of transferring the connection to the macrocell is taken.

2.2.3 Examples in literature

In [3] a hybrid predictive algorithm for handover between microcells and an overlaid macrocell is proposed which makes use of the mobile's position information. The idea is to have a macrocell overlapping multiple microcells, so the users travelling at high speed and therefore requiring frequent handovers and consequently high signalling load are transferred to the macrocell. This way the frequency of the handovers and the associated signalling load can be reduced.

The proposed Hybrid Predictive Handover (HPH) algorithm uses both positioning information and received signal strength information. A threshold distance is defined between the mobile terminal and the base station. When the mobile is in the handover area (the distance between the mobile and the base station is higher than the threshold distance), the signal strength is compared to a handover threshold and the handover decision is taken.

Mobile's positioning information must be reported to the base station together with the other measurements used for handover, which entails an increase of the signalling load directly proportional to the position update frequency. Nevertheless, up to a certain position update frequency, the signalling load of the hybrid handover algorithm is less than the signalling load if the HPH is not applied and the mobiles are always served by the microcells.

In [4] a handover decision algorithm that employs location awareness is proposed for Cellular Digital Packet Data (CDPD) networks, and its performance is compared to traditional algorithms via simulation. With this purpose, an algorithm residing in either the mobile terminal or the base station keeps track of the mobile's position and direction according to location information provided for example by a GPS receiver. Then either the mobile terminal (MCHO: mobile controlled handover) or the base station (MAHO: mobile assisted handover) can make a decision as to when it must hand off based on location information.

Location-aware handover entails multiple benefits. On the one hand, it can reserve resources in the candidate base stations ahead of time leading to performance enhancement in terms of reduced handover delay. The benefits are greater if more neighbouring base stations need monitoring (which is the case in traditional algorithms) since many of them can be discarded from the candidate list. In the case of MAHO, the mobile no longer has to report signal strength measurements from other base stations to its home base station but it may report its position periodically. This eliminates the need to continuously perform and process signal strength measurements saving battery power in the mobile. In addition, the number of control messages with the location aware algorithm is much less than that in the traditional handover.

The algorithm assumes that the mobile terminals are equipped with GPS receivers to provide positioning information. Handover decision is made by selecting the base station that has the closest distance to the mobile terminal. In order to avoid ping-pong effect, a distance hysteresis is used by comparing the current distance from the mobile terminal to the current cell with those of the neighbour

cells. If the distance of any new candidate cell is less than that of the current cell by the distance hysteresis, then the handover is performed.

The performance of location-aware handover algorithm has been compared to the performance of traditional algorithm used in CDPD through simulations. A simple scenario composed of four macro-cells has been considered, which is sometimes referred to as the canonical handover scenario. The mobile terminal is moving from BS1 to BS4 along a direct path, while base stations BS2 and BS3 are equidistant to this line of motion. In this situation, there are three equally likely handover alternatives when the mobile is somewhere near the centre of the line connecting BS1 and BS4, which allows a strict examination of handover performance when the user crosses the cell boundary region, specially at the centre point.

In this scenario, the average number of handovers and the average crossover point have been evaluated for both the traditional CDPD algorithm and the proposed location-aware algorithm. Mobile terminals enter the cell of BS1 according to a certain Poisson arrival rate and move along the directed path with constant speed randomly selected from a uniform distribution between 50 and 100 km/h. Concerning the location-aware algorithm, the positioning error has been characterized according to previous studies with a GPS Garmin 12XL receiver, while concerning the traditional algorithm the Hata model and lognormal shadow fading have been taken into consideration.

Simulation results show that the average number of handovers with the location-aware algorithm is far lower than that of the traditional algorithm, and consequently the signalling load is reduced. When the hysteresis level increases the average number of handoffs is reduced, although this also increases the crossover point and therefore the handoff delay. This handoff delay might cause the quality of service to deteriorate. Ideally, the appropriate crossover point should be at the cell boundary. The location-aware algorithm gives a closer crossover point than the traditional algorithm, both in terms of average value and standard deviation. Finally, another advantage of the location-aware handover is a lower complexity. From the position information, the location-aware algorithm can make the handover decision immediately, whereas the traditional algorithm must wait the RSSI average time and monitor signal strength in neighbour cells, which entails higher power consumption in the mobile equipment.

In [5] the previous study is enhanced in order to evaluate the performance of the location-aware handover algorithm in terms of system throughput. As throughput directly depends on received power, it could be expected that power-based algorithms would have a better performance in terms of throughput. The performance has been evaluated in the same canonical scenario as in the previous study, and presence of stationary users has been considered, which can be uniformly distributed over the outer, the inner or the whole area of the cell. Nevertheless, in any case considered system throughput obtained with the location-aware algorithm is higher than that with the traditional RSSI-based algorithms. Since the traditional handoff algorithms have many inappropriate handover decisions, a wrong BS can be selected for the handover resulting in a higher packet loss and therefore a throughput reduction.

2.3 Predictive resource reservation for mobility management

The objective of resource reservation for mobility management is to guarantee the quality of service of calls in progress when a handover takes place, minimizing the handover dropping probability and at

the same time optimizing resource availability, avoiding as far as possible the disconnection of existing calls and the blocking of new calls in the target cell.

2.3.1 Classic approaches

Several schemes have been proposed to prioritize handover calls in cellular systems. Handover prioritization schemes can be classified into two main strategies: static resource reservation strategies and dynamic resource reservation strategies. Static resource reservation strategies, such as Guarded Channel (GC) scheme, reduce the handover dropping probability through the reservation of a fixed set of resources for handover calls in each cell, so new calls will be blocked if available resources are less or equal to the reserved resources, while handover calls will be accepted provided that there are available resources. On the other hand, in dynamic resource reservation strategies the amount of reserved resources is dynamically adapted to traffic load in the adjacent cells. Furthermore, both strategies can be combined in hybrid schemes.

Dynamic resource reservation strategies can be further classified into non-shared reservation schemes and shared reservation schemes. In non-shared reservation schemes, each reserved channel can be exclusively used by the user that made the corresponding reservation, while in the shared reservation schemes reserved channels constitute a reservation pool and can be allocated to any user requesting a handover, regardless of whether the user made a successful reservation or not.

Given that the behaviour of the different mobile users in terms of mobility may vary and that in general traffic distribution is not uniform in space and time, static resource reservation schemes are not very efficient. In order to solve this problem, many dynamic resource reservation schemes have been proposed.

Shadow cluster technique introduces the estimation of future need of resources and dynamic reservation aiming to limit handover dropping probability due to handover. This scheme is based in the analysis of the potential influence of a mobile station (MS), characterized by the set of cells (cluster) the MS is expected to visit during the lifetime of the MS's connection, based on previous knowledge of the mobility pattern of the active MS. The main drawback of this scheme is that resources are reserved on each one of the cells in the cluster, which is often quite excessive and inefficient compared to other techniques, although it is effective in small cellular architectures.

More advanced solutions use the aggregate history of mobility observed at the cell level to predict (probabilistically) the direction of the MS and the time of the expected handoff. One problem with all history-based schemes is the overhead to develop, store and update traffic histories for the different cells. These histories can never be fully reliable as they continually go through short-term changes (e.g., diversion of traffic due to accidents), medium-term changes (e.g., traffic re-routing during road constructions and repair) and long-term changes (e.g., after opening a new shopping centre or closing down a military base).

Aiming to solve these problems, novel schemes are proposed in order to optimize the decision of which cells the MS is moving towards and consequently do not make unnecessary resource reservations as in the classic approaches. These schemes are known as predictive or adaptive resource reservation algorithms and are based on the estimation of the MS's position and the prediction of its trajectory.

2.3.2 Predictive Channel Reservation

Predictive Channel Reservation (PCR) based schemes use real-time position measurements to predict the future path of an MS and consequently make the necessary resource reservations. The utilization of real-time measurements introduces a set of considerations not addressed in history-based schemes such as monitoring changes in motion, cancelling false reservations, etc.

A first approach for position estimation is based on the measurement of received signal strength and the application of probabilistic propagation models to estimate the distance to different base stations. Received signal strength measurements are already used for other RRM procedures and algorithms (e.g. power control, handover...) although they suffer from different errors and biases (e.g. multipath, fading...) and entail a significant increase of power consumption. On the other hand, probabilistic propagation models also have a certain level of inaccuracy. These models are usually based on the extrapolation of empirical measurements made for certain positions and conditions and, although they are widely used for network design and frequency planning, they are not applicable to any situation. In order to reduce the level of uncertainty and inaccuracy of these models, algorithms based in pattern recognition techniques can be applied. Nevertheless, these algorithms are complex and require high processing capacity that is not available in mobile devices. Therefore, the efficient implementation of PCR schemes requires the accurate estimation of the MS's position.

In the PCR scheme, channel allocation decisions are based on the prediction (extrapolation) of the motion of MS's. Each MS periodically measures its position and orientation. The position measurement is made by using GPS, UWB, GSM, or any other technology, and the orientation can be easily obtained from the vector of two consecutive position measurements taken over a short time. The information is sent to the BS through an uplink message, or may be readily available if the positioning is done at the BS itself. The BS uses the position/orientation information to make extrapolation for the projected future path of the MS. The simplest prediction method only uses position and orientation. When the positioning technology becomes more advanced (e.g., with accurate estimation of velocity and acceleration), more complex extrapolation methods can then be used.

Based on the projected path, the next cell that the mobile is heading to is determined. When the MS is within a certain distance from the next cell (threshold distance), the current BS sends a reservation request to the new BS in order to pre-allocate a channel for the expected handoff event. A reservation may be deemed invalid (false reservation) at a later time. In this case, cancellation of reservation must be sent to de-allocate the reserved channel. Two types of cancellations are likely to occur:

- **Motion Cancellation:** Cancellations in this category occur when the mobile deviates from its predicted path and starts heading to a neighbouring cell different from the one that was computed in the latest prediction. The frequency of occurrence of motion cancellations depends primarily on the mobility pattern of the MS and the length of the interval between two successive position measurements.
- **Termination Cancellation:** This type of cancellation occurs when the ongoing call terminates before the mobile reaches the new cell boundary. In this case, a cancellation is sent to the new BS to de-allocate the channel reserved for this MS.

The concept of threshold distance (TD) is used to reduce the likelihood of false reservations and to control the timing of the submission of non-false reservations. TD, being a distance smaller than the radius of the cell, specifies an inner circle co-centred with and located inside the cell itself. If the mobile is currently located inside the TD circle, no reservation requests are sent by the BS. The value of TD needs to be carefully selected: larger values of TD may cause undesirable delay in the

submission of true reservations; smaller values of TD may cause frequent false reservations. A correct application of the threshold distance requires accurate knowledge of the mobile's position and direction. In Figure 2-1, the TD region in cell A is represented by a dotted circle.

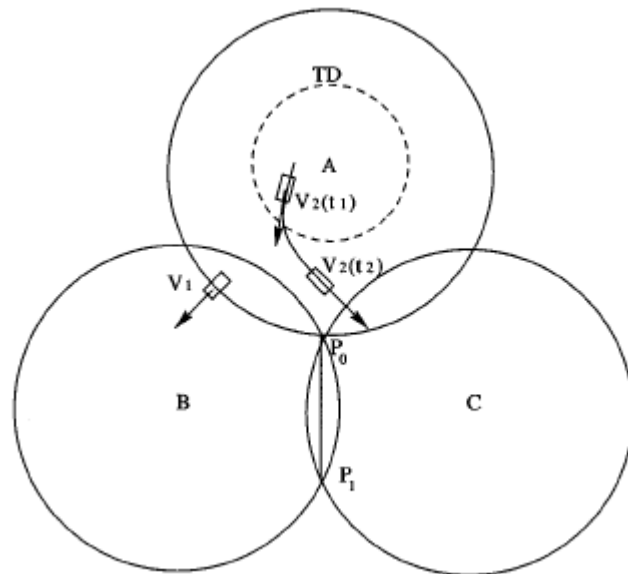

Figure 2-1: Threshold Distance (TD) concept [6]

Threshold distance can be also defined in relation to the target cell, and in that case it is often referred as reservation distance. A reservation region around each station can be defined, starting at the reservation distance D , as shown in Figure 2-2. The reservation distance D is always higher than the cell radius R . When a user with an established connection reaches the reservation point (i.e. the distance between the user equipment UE and the Base Station BS is lower than D), certain resource reservation will be made to this user.

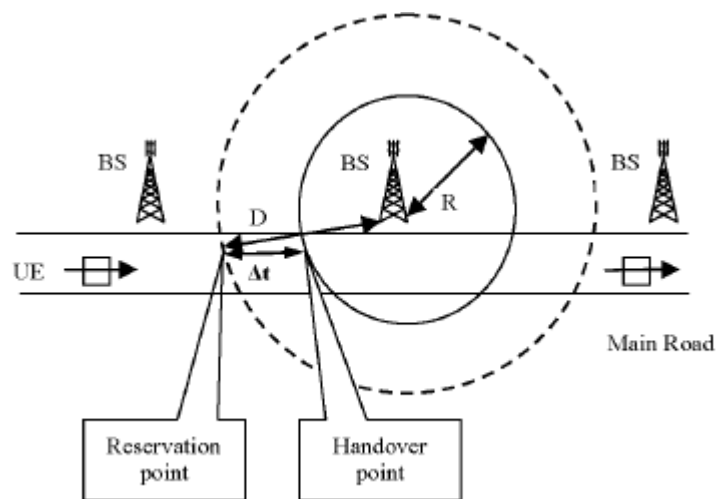

Figure 2-2: Reservation Distance concept [8]

As it was stated for threshold distance, the value of reservation distance is critic. A too low value of the reservation distance will cause a high dropping probability of handover calls, as less time is available in order to make the resource reservation and to free resources before the handover takes

place. On the other hand, for high values of the reservation distance D , high number of users will fall in the reservation region, which will increase the blocking of new calls in the target cell.

A problem associated with the use of a threshold distance or a reservation distance is that it does not take into account each individual MS's mobility behaviour separately. Suppose a MS moving with very low speed enters into the reservation area of a given cell. After the MS reserves a channel, it may need a long time to move into the cell. In this case, the time for which a channel is reserved for this MS will be too long, and thus the overall channel utilization will deteriorate. On the other hand, a MS moving with high speed will make the reservation just before moving into the cell, and can eventually be dropped if there are not available resources. Therefore, some authors propose the use of a threshold time instead of a threshold distance, so the reservation is made when, according to the estimated direction and speed, the expected remaining time for the handover is shorter than the threshold time.

2.3.3 Examples in literature

Several proposals of adaptive resource reservation algorithms for mobility management based on mobile stations' location information can be found in the literature, as well as different studies regarding the benefits that these schemes entail.

The concept of predictive resource reservation (PCR, Predictive Channel Reservation) was introduced in [6]. In the PCR scheme, channel allocation decisions are based on the prediction of the motion of each mobile station. With this purpose, each mobile station periodically measures its position using GPS or any other technology, and reports it to the base station that uses the position information to make extrapolation for the projected future path of the mobile. Based on the projected path, the next cell that the mobile is heading to is determined and when the mobile is within a certain distance (threshold distance) from the next cell, the current base station sends a reservation request to the new base station in order to pre-allocate a channel for the expected handoff event.

The basic PCR scheme is denoted as PCR1 and will be subsequently improved with different enhancements. In PCR1, the base station at any cell uses the following protocols to handle the four types of requests (handoff, new call, reservation and cancellation):

- Handover: If the handover call has a prior reservation, the corresponding allocated channel is assigned. If the handover call had no reservation, a channel will be allocated if there is any free channel. Otherwise the call will be dropped.
- New call: A channel will be allocated to the new call if there is any free channel. Otherwise the call will be blocked.
- Reservation: A channel will be reserved if there is any free channel. Otherwise the reservation request is ignored.
- Cancellation: The reserved channel is de-allocated.

The BS maintains the following two variables for each active mobile station: the id of the next cell to which mobile is heading to and a flag indicating whether the BS of the next cell has granted reservation for the mobile. When the BS collects a new position/orientation measurement for the mobile, it extrapolates the path of the mobile and computes the next cell. In case the next cell has changed, the reservation in the former next cell is cancelled if it existed and a reservation request is sent to the new next cell. In case next cell has not changed but there was no confirmed reservation, a reservation request is sent to the next cell.

The PCR1 scheme has the following problems:

- False reservations (i.e. when a reservation is made and later it is cancelled due to a change in predicted next cell) increase the blocking probability for both new calls and handoff requests
- The channel resources may be unnecessarily wasted when reservations are submitted too early
- Reservations submitted at time of congestion are ignored and do not achieve their intended goal of handoff prioritization.

In order to solve the limitations of PCR1, different enhancements to PCR1 are proposed.

The first enhancement is reservation pooling. Rather than strictly mapping each reserved channel to the mobile that made the reservation, the set of reserved (PCR) channels at any moment is used as a generic pool to serve handoff requests but not new calls. In this way, incoming handoff requests that failed to secure prior reservation may use one of the reserved channels. Two extensions of PCR1, called PCR2 and PCR3, were designed to offer two modes of sharing of PCR channels. The protocols for handling new calls and reservation requests are identical for all three schemes (PCR1, PCR2, PCR3), but each scheme has a distinct protocol for handling handoff requests. For PCR2, incoming handoff requests that did not make prior reservation may use one of the reserved channels only if no other free channel is available at that moment. In PCR3, handoff requests with or without prior reservation are treated equally; the reserved PCR channels, if available, are always used for handoff. Because of pooling, a handoff that secured a reservation may not find its reserved channel available at the actual time of handoff.

The second enhancement is the use of a threshold distance (TD) to reduce the likelihood of false reservations and to control the timing of the submission of non-false reservations. TD, being a distance smaller than the radius of the cell, specifies an inner circle co-centred with and located inside the cell itself. If the mobile is currently located inside the TD circle, no reservation requests are sent by the BS. The value of TD needs to be carefully selected as larger values of TD may cause undesirable delay in the submission of true reservations and smaller values of TD may cause frequent false reservations.

Another enhancement is the use of a hybrid handover prioritization scheme combining the PCR scheme with a static reservation scheme such as Guard Channel (GC). In this protocol, a fixed number of channels is exclusively set aside for handoff requests; the remaining channels are shared among new calls and handoffs. On the other hand, PCR protocol generates in each cell a pool of reserved channels whose size expands and shrinks based on the actual mobility dynamics that take place in the neighbouring cells. Integrating the GC mechanism (using smaller threshold values than in the pure GC scheme) into the predictive scheme enhances the capability of the PCR scheme in maintaining handoff prioritization at congested conditions without introducing excessive bias against new calls. The integrated scheme is called hybrid PCR, or simply HPCR. Three different versions of HPCR can be obtained based on the reservation pooling mechanism as discussed earlier, which are denoted as HPCR1, HPCR2 and HPCR3, respectively

Finally, for the PCR schemes described so far, the BS ignores reservation requests at time of congestion. Alternatively, these requests can be queued up in the new cell until free channels become available. The queue is referred as the reservation queue and the resulting scheme is denoted as PCRQ or HPCRQ when the reservation queue is incorporated into the hybrid scheme. When the reservation

queue is not empty, a channel released by a terminating call is added to the reservation pool and one reservation request is dequeued.

In order to evaluate the performance of each one of the proposed schemes, a set of simulations were performed. With this purpose, a cellular system composed of 5x5 circular cells with 1000 m. of radius, a TD equal to 0.8 of the cell radius, and 6 neighbour cells each was considered. Each cell is allocated 18 channels. New calls arrive according to a Poisson process and the duration of each call is exponentially distributed with a mean of 180 s. The mobility model represents the real-life motion of ground vehicles such as cars. In each update period, the MS may move in a straight line, in a curve or even stop for a short time according to certain probabilities. The direction of the motion after stopping may preserve the previous heading or may change to a new direction (e.g., left or right as in the case of cars). The average speed of MS is 18 m/s and the maximum speed is 24 m/s.

The basic PCR schemes were compared to a Fixed Channel Allocation (FCA) scheme with no reservation. In terms of handover dropping probability, the basic PCR1 scheme shows only very minor improvement over FCA during high traffic, but the other two pooling strategies (PCR2 and PCR3) show significant improvement over FCA for the entire range of traffic. However, the FCA scheme gave better new call blocking rates than the three simple PCR schemes. In fact, test results showed that the simple predictive scheme PCR1 is not much better than the non-predictive GC protocol.

Furthermore, the performance of the hybrid PCR schemes after adding reservation queuing (HPCRQ) was compared to the GC scheme. In terms of handover dropping probability, the three predictive schemes outperformed GC throughout the entire range of total reserved channels. Concerning new call blocking, HPCRQ blocking rates are very close to those of the GC scheme especially at high loads. From the user's point of view, forced termination of calls in progress is much more negative than blocking of new calls.

In [7] the proposed PCR scheme is combined with a dynamic allocation scheme based on Channel Borrowing (CB) instead of a static allocation scheme. The operation of the PCR-CB scheme is similar to PCR with the only difference that in case the cell receiving the reservation request cannot find any free channel, a channel can be borrowed for a neighbour cell with idle channels. With PCR-CB channel allocation adapts to traffic load in a predictive way, which entails a more efficient use of resources. Through simulations, it is shown that HPCR-CB schemes further reduce the handover dropping probability compared to HPCR schemes for a given number of reserved channels on each cell. Concerning new call blocking probability results are very similar for HPCR and HPCR-CB schemes.

In [8] a radio resource reservation algorithm that takes advantage of location-aware techniques in order to facilitate handovers in a WCDMA system, especially for users following straight trajectories, is proposed and evaluated. The proposed resource reservation algorithm takes into account the user location information in order to manage the available radio resources in a more efficient way. Moreover, the algorithm includes a prioritization of business users over consumer users.

The scenario considers a main road with different base stations close to it. Users are distributed both in the main road and in the rest of the scenario. Moreover, two kinds of users are considered: business users (higher priority) and consumer users (lower priority). The main objective of the proposed

reservation algorithm is to assure service to business users moving along a main road while at the same keeping the service of consumer users at a satisfactory level. To this end, the proposed algorithm defines a certain reservation region around each station, starting at the reservation distance D that is always higher than the cell radius R . When a business user in the main road with an established connection reaches the reservation point, certain resource reservation will be made to this user. The proposed algorithm considers accurate positioning measures to determine that the user enters the reservation region, which could be obtained with any of the existing location techniques.

In order for a handover to be admitted, there must be available resources at the new cell. As a WCDMA system is considered, reservation is made in terms of the number of required downlink orthogonal codes. When a main road business user reaches the reservation distance of a given cell, code availability check is carried out in this cell. If there are enough available codes in this cell, a code reservation is carried out for the current user in order to assure resources for the future handover request. On the other hand, if there is no code availability to make the code reservation to this user, the algorithm will firstly reduce the admission threshold for users demanding a new connection request in this base station in order to make room for the reservation in the future during the time before the handover. Finally, when the handover is requested, the user will be accepted, either if there are available codes or if it is possible to make room for the user by dropping some less priority users (i.e. consumer users).

The proposed algorithm has been evaluated through simulations in comparison with a scheme without predictive reservation and no priorities (reference algorithm) and with another without predictive reservation but with forced termination of less priority users to make room for business users (consumer dropping based algorithm). Moreover, different values for the reservation distance D have been considered. Consumer dropping based algorithm is able to minimize the business user dropping probability, at the expense of a high increase in the dropping of consumer users. Both business and consumer users dropping probabilities are minimized with the proposed predictive reservation algorithm, at the expense of increasing the new call blocking probability. Nevertheless, in terms of quality of service perceived by the user, it is better to reject an admission request instead of dropping an established connection.

In [10] the effect of the pre-reservation area size, and consequently the reservation distance, on handoff performance in wireless cellular networks is studied. In general, as the reservation area size increases, the probability that the handoff calls are dropped decreases initially. However, beyond a certain point, the performance begins to degrade due to a large number of false reservations. The optimal pre-reservation area size is closely related to the traffic load of the network and the mobile stations' mobility pattern, particularly their speed.

On the other hand, as an improvement to the PCR scheme, an adaptive channel pre-reservation scheme (ACR) is presented, which had been previously proposed by the authors in [9]. A limitation of the PCR scheme is that Threshold Distance is a constant parameter for all the mobiles independently of their mobility behaviour. This is not optimum, as the time for which a channel is reserved for a MS moving with low speed will be too long, while a MS moving with high speed will make the reservation just before moving into the cell. The proposed ACR scheme uses a threshold time instead of a threshold distance, and consequently channel reservation decisions are made based not only on each MS's current position and orientation, but also on the radial speed of the MS with respect to its next target cell. According to the position, orientation and speed of the mobile station, the time within

which the MS will reach this candidate cell is predicted. If the predicted time for handover is greater than the threshold time, the MS does not need to a channel reservation at the current time. If it is shorter, it means that the MS under consideration will move into the target cell soon, and a reservation request will be sent. As in the PCR scheme, functionalities such as reservation cancellation, reservation queuing and shared channel reservation (reservation pooling) are also integrated in order to improve the channel utilization of the cellular system.

ACR and PCR have been compared through simulations for mobile terminals moving with speed between 6 and 10 m/s. With this purpose, a threshold distance has been selected for the PCR scheme in order to get a similar handover dropping probability for both schemes. Therefore, comparison is established in terms of new call blocking probability. With a similar handover dropping probability, ACR presents lower blocking probability and therefore better performance. Furthermore, as the performance of ACR is independent of mobile's speed due to the use of threshold time, its performance is not degraded for lower or higher speeds. On the contrary, the value of threshold distance defined in the PCR scheme is only optimum for the considered mobility behaviour, and its performance would severely degrade if higher or lower speeds were considered.

In [11] a predictive resource reservation scheme called Predictive Mobility-Based Bandwidth Reservation (PMBBR) is proposed. In this scheme, the amount of bandwidth to be reserved in each cell is determined periodically. With this purpose, each mobile station obtains its position periodically and, based on the history location information, a mobile agent predicts the future moving speed and direction of each user. With this information, the next cell along the mobile's path and the estimated time for the handover are obtained. The handover probability is defined as the probability that the residual call lifetime is longer than the expected time for the handover. A reservation advance threshold time is also considered. Finally, in each cell the total amount of bandwidth to be reserved is calculated as a portion of the sum of the bandwidth required by each call that, according to the prediction, is going to be transferred to that cell within the threshold time, weighted by their respective handover probabilities.

In [12] a predictive reservation scheme called Mobility-aided Adaptive Resource Reservation (MARR) is proposed. The area of a cell is divided into the reservation zone and the non-reservation zone according to a threshold radius, similar to the concept of threshold distance. Position, direction and mobility ratio (defined as the ratio of the mean call holding time to the mean cell dwell time) of the mobiles stations are periodically calculated and the trajectory of the mobile stations within the reservation zone is extrapolated. Finally, the amount of bandwidth reserved for each cell is dynamically adapted.

Two possible schemes are proposed for the calculation of the amount of bandwidth reserved for each cell. In the first approach, termed as MARR1, it is assumed that the location of MSs can be accurately predicted by positioning systems, thus the moving direction of MSs can be accurately predicted by extrapolating the trajectory of MSs at each probe time. Therefore, the target cell is only set to reserve bandwidth for future handoff connections. The amount of bandwidth reserved in a cell is calculated as the sum of the bandwidth required for each connection within the reservation zone and targeted to that cell weighted by the reservation probability. The reservation probability depends on two factors, the mobility ratio (that accounts for call duration and dwell time) and the expected distance to the cell

centre at the probe time according to the current position and speed (so the reservation probability depends on mobile's speed, thus mitigating the problem associated with the use of a threshold distance). The second scheme, denoted as MARR2, the inaccuracy of position estimation and/or trajectory extrapolation is considered. Therefore, resources are not only reserved in the predicted target cell, but only in other possible target cells (sub-target cell). Then the bandwidth reserved on each cell is also weighted by a direction factor that has different values for target and sub-target cells.

The performance of MARR1 and MARR2 has been evaluated through simulations and compared to the Fixed Bandwidth Reservation (FBR) scheme similar to the Guard Channel scheme and with the PCR predictive scheme. For high traffic load conditions, the performance of MARR schemes is better both in terms of handover dropping probability and new call blocking probability.

In [13] a reservation scheme called, Distributed Call Admission Control with Aggregate Resource Reservation, also denoted as Virtual Reservation (VR), is proposed. This scheme uses mobility prediction based on mobile positioning system location information and takes into account the expected bandwidth to be used by calls handing over from neighbouring cells within a configurable estimation time window. VR scheme aims to estimate the global amount of resources to be reserved in each cell instead of per-user reservation, thus avoiding the consequent signalling overhead.

With this purpose, it is assumed GPS receivers integrated with the mobile equipment are used to get positioning information. Periodically, each mobile sends GPS location and session load information to the base station. With this information, the next cell likely to be visited by a mobile user is determined. The estimated time to handoff is also calculated according to the mobile's trajectory and speed. When the estimated time to handoff is below a pre-established threshold level, the reservation is then made. Otherwise, a reservation proportional to the estimated remaining time (TR) is made. This way, each cell periodically estimates the aggregated load that is likely to be transferred to its neighbour cells within the current time window, and reports it to its neighbour cells. Consequently each cell estimates the amount of bandwidth that should be reserved according to the reports received from its neighbour cells.

The proposed VR scheme has been compared through simulations with the fixed guard channel (GC) and other optimized dynamic reservation-based proposals present in the literature, such as ACR, showing a better performance in terms of handover dropping probability and network utilization. Furthermore, VR requires much less signalling than ACR scheme, especially for high traffic load conditions.

In [14] a dynamic predictive resource reservation scheme is proposed. By means of a GPS receiver integrated in each mobile terminal that enables it to obtain its own position information, the mobile is able to estimate its trajectory and speed and to predict the estimated remaining time to handoff and the target handoff cell, based on approximated cell boundary information that is periodically broadcasted to all users in each cell. If the remaining time to handoff is shorter than a threshold time, known as the Remaining Time to Handoff Threshold (RTHT), the mobile terminal informs the BS about its predictions. Upon receiving this information, the BS will request the consequent resource reservation in the target cell, and the reserved bandwidth will be added to the reservation pool. In order to avoid the loss of efficiency associated with the mobile terminals that change their trajectory or calls that end before they arrive at the new cell, the reserved bandwidth is only increased by a fraction of the actual

bandwidth requirement which is referred to as reservation ratio (RR). The reservation ratio can have different values for different traffic classes and in general the values of RR are adjusted dynamically based on the measured values of the dropping probability for each traffic class. The main novelty of the proposed scheme is that, unlike most existing work on trajectory prediction and cell residence time distribution modelling in wireless networks that assume either hexagonal or circular cells, the proposed prediction algorithm caters for irregular cell boundaries, which is a much more realistic approach.

This scheme is used by the same authors as basis for the Road Topology Based (RTB) dynamic resource reservation scheme, which is proposed in [15] and is probably the most complete scheme proposed to date. The main enhancements introduced compared to the scheme proposed by the authors in [14] are the use of topological information (e.g. roads, etc.) for path prediction and the use of both incoming and outgoing handover prediction to improve the efficiency of the scheme.

In the proposed scheme, each base station receives periodic position updates from the mobile stations with an active call within its cell. Moreover, each base station has a database with information about the roads in its coverage area. The road between two neighbouring junctions is referred to as a road segment. The database stores the coordinates of each segment, the identity of neighbouring segments at each junction, the transition probabilities between neighbouring segments (computed from the paths taken by previous MSs), statistical data of time taken to transit each segment, and statistical data regarding possible handoffs along each segment, such as probability of handoff, time in segment before handoff, and handoff positions. Segments and junctions can be easily extracted from existing digital road maps previously designed for GPS-based navigational devices, while the other database entries need to be updated regularly to adapt to the current traffic conditions.

In order to perform the predictions, the base station maps the current position of each mobile onto the correct road segment within the road topology database, estimates the current speed and predicts the possible routes of the mobile. For each route leading to a handover within a certain threshold time, the BS computes the target cell, the probability that the prediction is correct and lower and upper bounds for the remaining time to handoff namely lower prediction limit (LPL) and upper prediction limit (UPL). Then each base station transmits its handover predictions, provided that remaining time to handoff is shorter than the threshold time, to its neighbouring cells, including the LPL and the required bandwidth weighted by the prediction probability. Threshold time can have different values in each cell and is dynamically adjusted in order to keep a certain handover dropping probability.

This way, each cell has the prediction of incoming handovers and outgoing handovers for a time interval of duration equal to threshold time. Both incoming and outgoing predictions are sorted according to the remaining time to handoff, considering the LPL for the incoming handovers and the UPL for the outgoing handovers, in order to minimize the dropping probability due to possible inaccuracy of the estimated time to handoff. According to the established temporal order, the handover list is processed in order to calculate the reservation bandwidth, adding the bandwidth of the incoming handovers (weighted by the handover probability) and subtracting the bandwidth of the outgoing handovers (weighted by the handover probability). The maximum required bandwidth obtained during the process will be the bandwidth that is necessary to reserve.

The performance of the proposed scheme has been evaluated through simulations and compared to other resource reservation schemes, in terms of handover dropping probability and new call blocking probability. Tested schemes include several variants of RTB with different assumptions (realistic, with route knowledge and ideal), the scheme proposed in [14] denoted as LE (Linear Extrapolation), a

predictive scheme based on statistical information (Choi's AC1), a reactive reservation scheme based on the dropping probability and a static reservation scheme (similar to GC). The position-based prediction schemes (LE and RTB) outperform the other schemes as for a certain fixed dropping probability a lower blocking probability is obtained. Moreover, through the use of topology information, RTB presents a higher efficiency than LE. On the other hand, the benefits of using both incoming and outgoing handover predictions to determine the reservation bandwidth instead of using incoming handover predictions only are also demonstrated through simulation results.

2.4 Load control and balance in cellular based networks

2.4.1 Load control and balance

The objective of Load Control (LC) function is to monitor and control the traffic load in the cells under a common base station controller in order to assure that the system is not overloaded and to guarantee the appropriate Quality of Service (QoS) levels. This information is reported to the admission control and the scheduler for radio resource management.

In case an overload or congestion situation is detected, Load Control must take the necessary actions in order to regain a suitable load level. With this purpose, Load Control coordinates with other RRM functions such as admission control, handover control, power control and scheduler in order to take actions such as reallocating some user terminals in other cells, reducing the data rate or quality level of some connections or even forcing the termination of connections of non-priority users.

In order to maximize the capacity of a cellular network without suffering congestion, load balancing strategy attempts to distribute the traffic load among the cells as uniformly as it is possible. Nevertheless, this is not always possible as in general user and traffic distribution is not uniform and therefore some cells will present a high density of users while others will have a low utilization level.

In this sense, the use of Fixed Channel Allocation (FCA) schemes is not very efficient. Dynamic Channel Allocation (DCA) maximizes global network capacity, but has higher complexity and is not suitable for systems with limited reuse of resources. Hybrid Channel Allocation (HCA) schemes combine both schemes in order to solve their limitations, as Borrowing Channel Assignment (BCA) scheme, which allows borrowing unused channels from neighbour cells.

In order to balance traffic load or to solve specific congestion situations different strategies can be implemented. The performance of these strategies could be enhanced through the use of location information.

- Adaptation of resource allocation to the geographic distribution of traffic load, so the cells supporting a higher traffic load are allocated a higher amount of resources. User's position information would provide exact knowledge of the geographical distribution of traffic.
- Reallocation (as far as possible) of terminals near the cell-edge of cells with high traffic load in neighbour cells with higher availability of resources and able to provide similar quality of service. User's position and trajectory information would be helpful in order to identify which users are more suitable to be reallocated and to which cell should be transferred.
- As it is proposed [17], using smart antennas it is possible to dynamically change cell size and shape, reducing the coverage area of cells supporting a high traffic load and expanding the coverage area of

neighbour cells, so some users of the congested cell would be transferred to neighbour cells. With this purpose, knowledge of the geographical distribution of traffic is necessary.

Furthermore, positioning information is not only useful for load balancing, but it can also be used for prediction of future traffic load on each cell. As for handover and predictive resource reservation, knowledge of user's position and trajectory allows predicting not only incoming handover calls, but also outgoing handovers and the time that the calls will stay in the cell. This way and together with other statistical parameters related to new calls generation and call duration, it is possible to estimate the traffic load that a cell is going to support in a certain time interval and to detect future congestion situations, taking appropriate actions in advance (e.g. adaptation of resource allocation to cells, reallocation of cell-edge terminals, blocking admission of new calls...) in order to prevent congestion to occur.

2.4.2 Examples in literature

Although there are not many works related to location-aware load control in the literature, the use of location information in load control for load balancing and optimum resource allocation is considered one of the possible applications of location awareness in radio resource management [16].

For example, in [17] a novel geographic load-balancing scheme for cellular networks that intelligently changes cellular coverage according to the geographic traffic distribution in real time is proposed. The performance of the whole cellular network is improved by contracting and shaping the antenna radiation pattern around a traffic "hot spot" and expanding adjacent cells coverage to fill in the coverage loss. Mobile's position information is used to find the desired coverage patterns to serve a current traffic demand pattern. The results from computer simulations show that call blocking rate for the scheme using intelligent geographic load balancing is much lower than the conventional one, especially when there are some hotspots. This demonstrates that by the use of intelligent geographic load balancing, the system capacity can be improved significantly for non-uniformly distributed traffic.

On the other hand, some works propose the use of traffic load prediction for the implementation of optimum channel allocation schemes that can adapt to the geographic traffic distribution. In general, the authors use statistic methods for mobility and load prediction although, as for predictive resource reservation, the use of position and trajectory information of the mobile users would lead to a much more accurate prediction and therefore to a better performance of these predictive schemes.

In [18] a mobility prediction scheme is proposed for computing the likelihoods of the next-cell transition, along with anticipating the duration between the transitions. The proposed mobility prediction scheme is not based on location information, but on mobility history patterns using a Markov renewal process. Furthermore, the proposed model can be used for predicting the activity and traffic demand at each location in the network. Such information can assist with optimizing the allocation of the network's resources.

In [19] an improved Borrowing Channel Assignment (BCA) scheme using traffic load prediction is proposed. Borrowing channel assignment (BCA) provides a higher efficiency and flexibility than fixed channel allocation (FCA) with a lower complexity than dynamic channel allocation (DCA). However, in the case of patterned traffic load, BCA is not efficient to further enhance the performance because some heavy-traffic cells are unable to borrow channels from neighbouring cells that do not have unused nominal channels. The performance of the whole system can be raised if the short-term traffic

load can be predicted and the nominal channels can be re-assigned for all cells. The authors propose a probabilistic traffic load prediction algorithm and a channel re-assignment scheme. As a result of prediction and re-assignment, the heavy-traffic cells can obtain more nominal channels while the numbers of the nominal channels in other light-or-medium-traffic cells are decreased accordingly. Simulation results corroborate that the proposed method delivers significantly better performance than BCA for patterned traffic load situations, and is virtually as good as BCA in the other situations analyzed.

2.5 Adaptive resource allocation for Intersystem-handover

2.5.1 Overview

Mobility management is one of the major tasks of cellular networks. It mainly refers to the handover between two cells in case of a intrasystem handover, or between two RATs (Radio Access Technologies), in case of a intersystem handover. This section investigates an adaptive resource reservation to reduce the CBP (Call Blocking Probability) and CDP (Call Dropping Probability) of the system. The adaptive resource reservation method is based on the location-aware mechanism of UMTS (Universal Mobile Telecommunications System) and GSM (Global System for Mobile Communications). In the following, the location-aware algorithm in UMTS networks and the adaptive resource allocation algorithm are described. The mobility model and the simulation results are displayed in 2.5.4.

2.5.2 Location-aware algorithm in UMTS network

User Equipment (UE)-assisted LCS (Location Service) in UMTS deploys the OTDOA (observed time difference of arrival) method to determine the position of the UE. OTDOA performs measurements in the target UE. The results of the measurements shall be delivered to the RNC (Radio Network Controller). The RNC calculates the position of the target UE according to the OTDOA and the RTD (real time difference). The detailed information about the OTDOA localization can be found in [20].

2.5.3 Adaptive resource allocation algorithm

In this deliverable, adaptive resource allocation algorithm for the Intersystem-handover (IS-HO) is investigated. We focus on the hard handover between two different RATs (GSM and UMTS).

2.5.3.1 UMTS to GSM IS-HO

Due to the close loop power control in UMTS, the uplink power transmitted from UE shall be increased when the UE moves away from the Node B. The uplink power P is measured by the UE each timeslot (0,67 ms) in one UMTS cell, then the position D , velocity V and the acceleration A of the UE are also measured by the UE. P_{th} is the power threshold, which shall be set in the RNC. D_{th} is the position threshold, which shall be set according to the D , V and A . The position of Node B is D_N , which is known by the RNC. The IS-HO shall happen if the following conditions are satisfied:

- $P \geq P_{th}$
- $|D - D_N| \geq |D_{th} - D_N|$

Then the RNC sends IS-HO request to the BSC (Basestation Switching Center) of the GSM system through the CN (core network). BSC in GSM decides if the resource (channels) in GSM can be allocated to the new coming UE.

2.5.3.2 GSM to UMTS IS-HO

The position D , velocity V and the acceleration A of the UE are measured by the UE itself and reported to the BSC. The BSC instructs the UE to measure the $RPSS$ (Received Pilot Signal Strength) from the coming UMTS cell according to D , V and A . It assumes that D_{th} is the position threshold, and D_N is the position of the Base Station. The $RPSS$ from the coming UMTS cell shall be measured if the following condition is satisfied:

- $|D - D_N| \geq |D_{th} - D_N|$

If $RPSS \geq RPSS_{th}$, the IS-HO shall happen. Then the BSC in GSM sends the *A-HO-REQUIRED* signal to the MSC. After the RNC in UMTS receives the *lu-RELOCATION-REQUEST*, the RNC shall decide if there are free channels for the new coming UE.

2.5.4 Simulation

2.5.4.1 Mobility model

For simulations, a seven-cells model has been considered due to the equilibrium of the cluster.

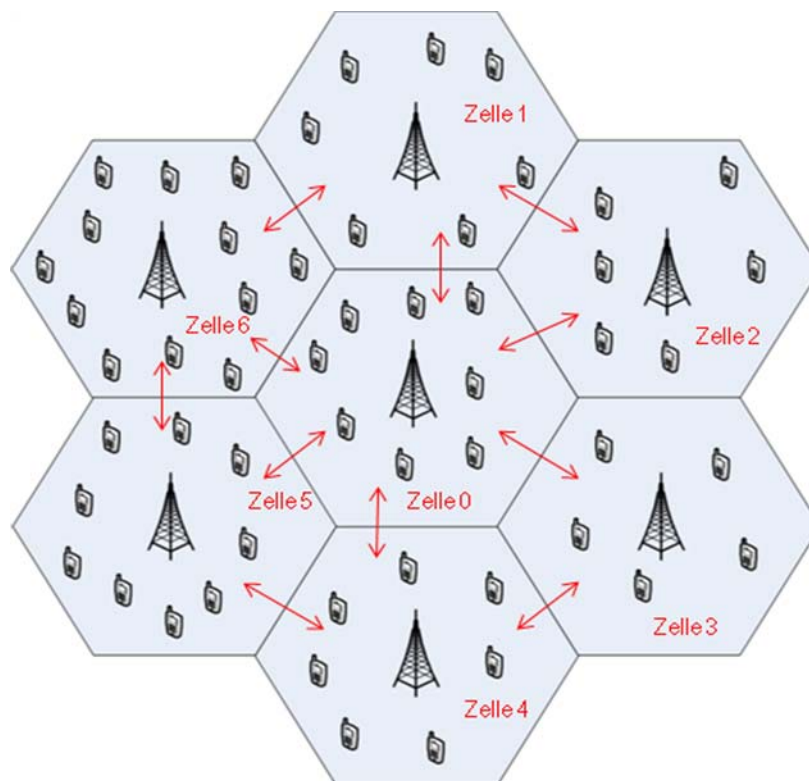

Figure 2-3: Cluster of the seven cells. Red arrows represent handover between two cells

Figure 2-3 illustrates the seven-cells model, which consists of one central cell, cell 0, and the six marginal cells, cell 1-6. Cell 0 has possibilities of handover to six marginal cells while each marginal cell has possibilities of handover to three adjacent cells. The call arrival is considered as Poisson

Process with expected arrival rate λ . C_{cl} is the capacity of the cluster. Let's assume that there are N UEs ($N \leq C_{cl}$) in this cluster, which are in idle mode. Since the UE are independent from each other, the probability of K UEs arriving in this cluster within unity time can be expressed as:

$$P = \frac{(N\lambda)^K e^{-(N\lambda)}}{K!} \quad (1)$$

Time duration between two call arrivals is considered as exponential distribution with the expectation $1/\lambda$. The dwell time is the time duration, with which one call stays in one cell. The call duration is the time duration, with which the call lasts. The dwell time in one cell is considered as exponential distribution with the expectation $1/\mu_d$.

$$f(t_d) = \mu_d e^{-\mu_d t_d} \quad (2)$$

It assumes that the capacity of each cell is C (number of channels). Hence, the status of the cell i v_i can be defined as $v_i \in \{0, 1, 2, \dots, C\}$, $i = 0 \dots 6$. The status of the cluster V can be represented as:

$$V_s = [v_{0s} v_{1s} \dots v_{6s}] \in \{V_0 V_1 \dots V_{S_{\max}}\} \quad (3)$$

From (3), we can get that there are totally $(C+1)^7$ status in this cluster.

$$S_{\max} = (C+1)^7 \quad (4)$$

Following behaviours lead to the transition from V_i to V_j :

- New call with the arrival rate $N\lambda$
- Call completion with the rate λ_{End}
- Handover within this cluster with the rate λ_{IH}
- Handover to another cluster with the rate λ_{Handoff}
- Handover from another cluster with the rate λ_{Handin}

It assumes that N_s is the number of occupied channels in the status V_s . We can get

$$N_s = \sum_{i=0}^6 v_{is} \quad (5)$$

$$\lambda_{\text{End}} = \sum_{s=0}^{S_{\max}} N_s P(V_s) \mu_c \quad (6)$$

$$\lambda_{\text{Handoff}} = \sum_{s=0}^{S_{\max}} \sum_{i=1}^6 \frac{1}{2} N_s P(V_s) \mu_d \quad (7)$$

$P(V_s)$ is the probability of the status V_s . It can be determined with the iteration method noted in [21]. Due to the equilibrium of the cluster, the relationship between handover to another cluster and the handover from another cluster can be expressed as

$$\lambda_{\text{Handoff}} = \lambda_{\text{Handin}} \quad (8)$$

The arrival call in this cluster is considered as Poisson Process with the expected rate $N\lambda - \lambda_{\text{End}}$. In the status V_s , the new call arrival in the cell 0 is a Poisson Process with the expected rate $N\lambda / 7$. The call completion is with the rate $\lambda_{0,\text{End}}$,

$$\lambda_{0,\text{End}} = \sum_{s=0}^{S_{\max}} N_{0,s} P(V_s) \mu_c \quad (9)$$

Handover to cell 1 to 6 with the rate $\lambda_{0,\text{Handoff}}$,

$$\lambda_{0,\text{Handoff}} = \sum_{s=0}^{S_{\max}} N_{0,s} P(V_s) \mu_d \quad (10)$$

Handover from cell 1 to 6 with the rate $\lambda_{0,\text{Handin}}$,

$$\lambda_{0,\text{Handin}} = \frac{1}{6} \sum_{s=1}^{S_{\max}} \sum_{i=1}^6 v_{s,i} P(V_s) \mu_d \quad (11)$$

Hence, we can get the total arrival rate of the call in cell 0 $\lambda_{0,\text{sum}}$,

$$\lambda_{0,\text{sum}} = N\lambda / 7 - \lambda_{0,\text{End}} - \lambda_{0,\text{Handoff}} + \lambda_{0,\text{Handin}} \quad (12)$$

In status V_s , the new calls arrival in the cell 1 to 6 with the expected arrival rate $N\lambda / 7$. The call is terminated with the expected call completion rate $\lambda_{i,\text{End}}, i=1 \dots 6$,

$$\lambda_{i,\text{End}} = \sum_{s=0}^{S_{\max}} N_{i,s} P(V_s) \mu_c, \quad i=1, 2, 3 \dots 6 \quad (13)$$

Handover from the adjacent cells with the expected rate $\lambda_{i,\text{Handin}}, i=1 \dots 6$,

$$\lambda_{i,\text{Handin}} = \frac{1}{6} \sum_{s=0}^{S_{\max}} (v_{0,s} + v_{i-1,s} + v_{i+1,s}) P(V_s) \mu_d, \quad i=1 \dots 6 \quad (14)$$

Hence, we can get the total arrival rate of the call in cell 1 to 6 $\lambda_{i,\text{sum}}$,

$$\lambda_{i,\text{sum}} = N\lambda / 7 - \lambda_{i,\text{End}} - \lambda_{i,\text{Handover}} + \lambda_{i,\text{Handin}}, \quad i=1, 2 \dots 6 \quad (15)$$

Therefore, we can get the CBP (Call Blocking Probability):

$$\begin{aligned} CBP &= \left[\sum_{k=0}^{7C} \frac{(N\lambda - \lambda_{\text{End}})^k e^{-(N\lambda - \lambda_{\text{End}})}}{k!} \right] P + 1 - \sum_{k=0}^{7C} \frac{(N\lambda - \lambda_{\text{End}})^k e^{-(N\lambda - \lambda_{\text{End}})}}{k!} \\ P &= \left[1 - \sum_{k=0}^c \frac{(\lambda_{0,\text{sum}})^k e^{-\lambda_{0,\text{sum}}}}{k!} \right] + \sum_{i=1}^6 \left[1 - \sum_{k=0}^c \frac{(\lambda_{i,\text{sum}})^k e^{-\lambda_{i,\text{sum}}}}{k!} \right] \end{aligned} \quad (16)$$

2.5.4.2 Simulation results

We set the mean dwell time to 200 s ($\overline{T_D} = 200$), mean unencumbered session duration to 100s ($\overline{T} = 100$) and the number of noncommunicating platforms per cell was 50 ($v_0 = 50$).

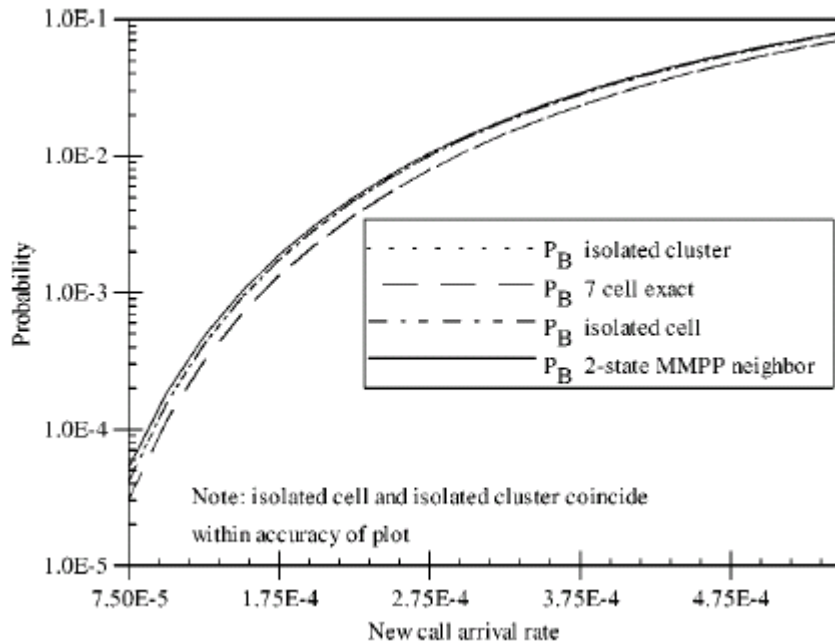

Figure 2-4: Blocking probabilities. $\bar{T} = 100$, $C=5$, $\nu_0 = 50$

Figure 2-4, shows the CBP under 4 different scenarios: isolated cluster, 7 cell exact, isolated cell and 2-state MMPP neighbourhood.

2.6 Resource allocation and interference coordination in OFDMA-based networks

Orthogonal Frequency-Division Multiple Access (OFDMA) is a multiple access scheme based on OFDM digital modulation where subsets of carriers are allocated to the different individual users. This scheme is used in different systems such as IEEE 802.16e Wireless MAN (Mobile WiMAX), IEEE 802.20 Mobile Wireless MAN (MBWA), and 3GPP Long Term Evolution (LTE). Concerning LTE, OFDMA is proposed in E-UTRA (Evolved UMTS Terrestrial Radio Access) as an enhanced radio interface alternative to WCDMA, used in 3G.

In order to reach a spectral efficiency similar to WCDMA, frequency reuse factor should approximate to 1. But in OFDMA networks with frequency reuse of 1 the throughput at the cell border is very much limited by interference. In the downlink, since the neighbour cell transmits on the same band, SIR on the cell-edge approximates to 0 dB. So the interference by the neighbour cell limits the throughput. This situation is undesirable as bit rate and QoS for all the connections should be guaranteed in any case.

Same problem occurs in the uplink. If a terminal uses a certain frequency pattern for data transmission to its base station this frequency pattern may be used in the neighbour cell for another uplink connection. So e.g. if terminal T_2 uses a frequency pattern to send to base station B and near to the cell border the terminal T_1 in a neighbour cell uses this same frequency pattern to transmit to base station A, the base station B experiences interference from T_1 when it tries to receive the frequency pattern from its client terminal T_2 . This is shown graphically in Figure 2-5.

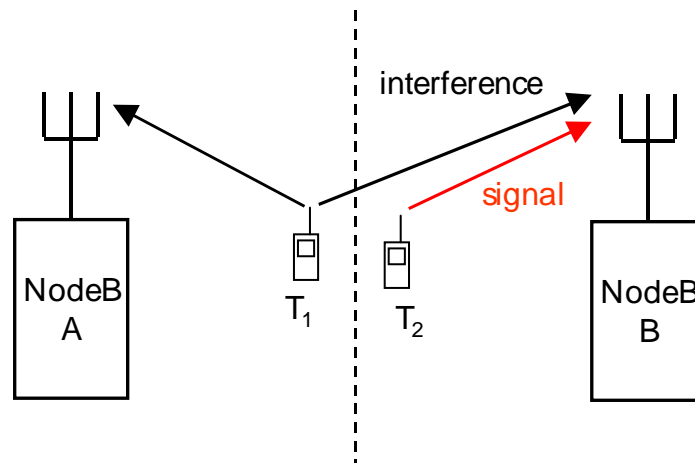

Figure 2-5: Cell-border interference users in the uplink [38]

If synchronization for the cells cannot be assumed, interference avoidance has to be based only on distribution of different frequencies and not on distribution of different time slots. In case of OFDMA the terminals in a cell use different frequency patterns to achieve multiplexing of the terminals.

Nevertheless, interference in an orthogonal access scheme is predictable, designable and avoidable. Now OFDM allows for interference avoidance in contrast to CDMA. This is true since in OFDM the orthogonality of the individual subcarriers after channel transmission is preserved, provided that cyclic prefix duration is higher than channel delay and there is no significant frequency drift, in contrast to CDMA where orthogonality in reception is lost due to multipath propagation and lack of synchronization. This offers the possibility in OFDM to predict and avoid interference to improve the situation at the cell border.

2.6.1 Classic approaches

There are three basic methods in order to combat co-channel interference in cellular networks: interference avoidance, interference averaging and interference cancellation.

Interference avoidance schemes try to coordinate the use of frequency resources in different cells in order to avoid collisions between the same frequencies used in neighbour cells. This can be done either in a static way by allocating different frequencies to neighbour cells, which implies a frequency reuse factor (FRF) greater than one, or in a dynamic way, with an intelligent scheduler taking care of the collisions. Considering the signalling overhead and the complexity to implement the intelligent scheduler, only the static method is widely adopted in practical network deployments. In conventional 2G systems, only particular sets of integer frequency reuse factors (IFRFs) are adopted, while up-to-date systems such as IEEE 802.16e and 3GPP LTE consider the use of fractional frequency reuse factors (FFRF). On the other hand, the use of positioning information could reduce the signalling overhead and complexity of dynamic coordination systems.

Interference averaging or randomization schemes try to statistically average the interference so that the interference level remains as constant as possible, both in frequency domain and in time domain. This way, the concentration of interference on specific users or time intervals, which would cause important degradation on those users, is avoided. With this purpose, interleaving, scrambling, subchannel permutation and frequency hopping techniques are used.

Finally, interference cancellation schemes try to reduce the interference produced by neighbour cells. An example of interference cancellation schemes is interference suppression through the use of multiple antennas and MIMO techniques.

Focusing on interference avoidance solutions, a closer look to the evolution of frequency planning schemes more commonly used in cellular systems is provided.

As it was previously stated, in 2G cellular systems (GSM...), mutual interference between neighbour cells was controlled setting the frequency reuse factor (FRF) to integer values (e.g. 3, 7...). Cells are consequently grouped into clusters of 3 or 7 cells, and each cell is allocated orthogonal sets of $1/3$ or $1/7$ of the total frequency resources. Allocated resources cannot be used by any neighbour cell closer than a certain distance (reuse distance), thus reducing co-channel interference. Nevertheless, this strategy entails that $2/3$ or $6/7$ of the frequency resources, respectively, cannot be used by each one of the cells, which results in a very low spectral efficiency.

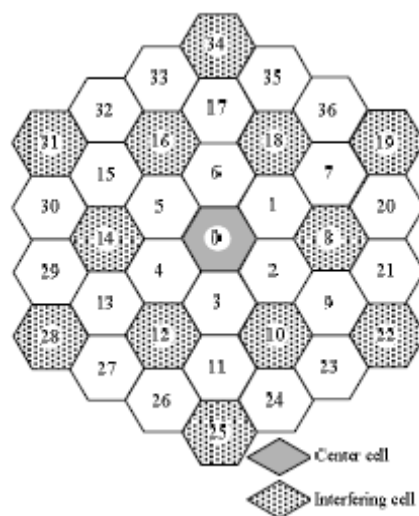

Figure 2-6: Frequency reuse scheme at cell level with FRF=3 [39]

IEEE 802.16 (WiMAX) system two techniques are proposed in order to reduce interference between neighbour cells. On the one hand, the use of frequency reuse factors higher than 1 allocating different frequency resources to each cell, and on the other hand the use of distributed subchannel permutation schemes. TDD OFDMA frame structure used in mobile WiMAX is divided into different subchannels, comprising of multiple OFDM subcarriers, in frequency dimension, and OFDM symbols in time dimension. In the process of subcarrier allocation, subcarriers are selected pseudo-randomly, according to a predefined permutation base (PermBase), in order to constitute a logical subchannel. Two basic modes of distributed subcarrier permutation are defined: full usage of subchannels (FUSC), if all the available subchannels are considered, and partial usage of subchannels (PUSC), if a subset of the available subchannels is considered. These permutation modes can be implemented using the same base permutation in each cell or different base permutations in different cells.

In practical network deployment, both techniques are usually adopted simultaneously to better combat inter-cell interference. There are multiple available combinations of frequency reuse and subcarrier permutation patterns for frequency planning. As an example, considering 3-sector cells, PUSC scheme can be combined with a frequency reuse factor of 3 at sector level. Therefore, each sector is allocated a subset of $1/3$ of the total subchannels, thus avoiding inter-sector interference and reducing interference

from neighbour cells. At cell level the whole frequency spectrum is used, although only a subset of total subchannels is available in each sector, thus reducing the cell capacity.

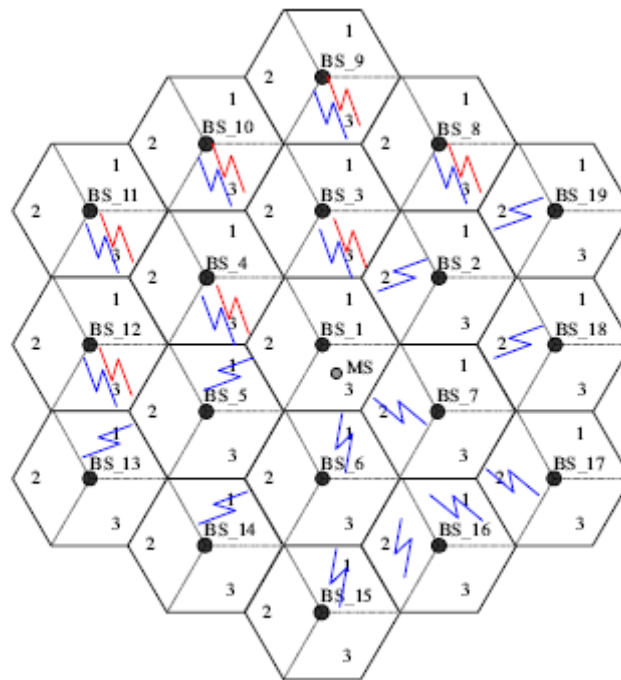

Figure 2-7: Co-channel interference on MS for FRF=1 (blue lines) and FRF=3 (red lines) [25]

In the design of up-to-date systems, Fractional Frequency Reuse (FFR) schemes are being widely adopted. In this scheme the cell is divided into two regions: cell-centre region and cell-edge region. In the cell-centre region the received signal strength is high and users are consequently less sensitive to interference, so a frequency reuse of 1 can be applied. On the other hand, in the cell-edge region users are likely to suffer from high co-channel interference so a frequency reuse factor higher than 1 is applied. This way the co-channel interference for cell-edge users is decreased compared to systems with reuse of 1 without a big loss in spectral efficiency, which was the drawback of systems with integer frequency reuse factor higher than 1.

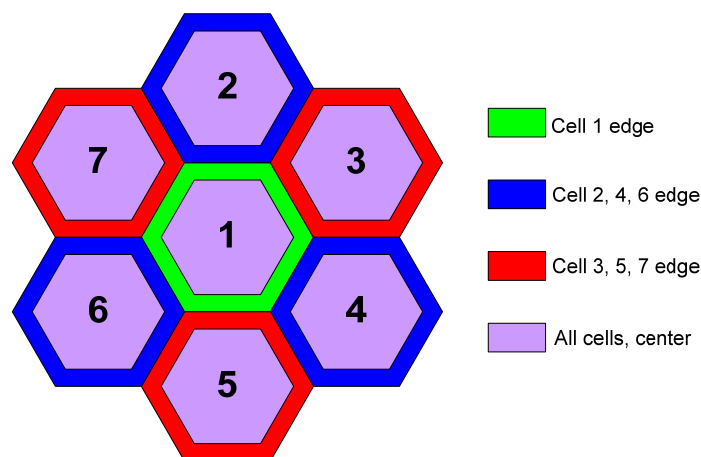

Figure 2-8: FFR scheme at cell level [32]

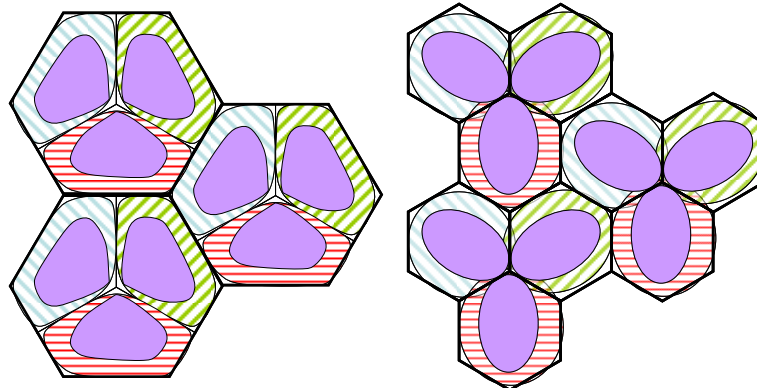

Figure 2-9: FFR schemes at sector level

There are two main types of FFR schemes [22]:

- Soft frequency reuse. For each cell in the network, a part of the frequency band is reserved for the cell edge users, on which the transmission power is amplified. Centre-cell users can use the whole frequency band with limited power. In a tri-sector network, the reserved part is normally $1/3$ of the total frequency band and is referred as cell edge band, since the cell edge users are restricted to use this frequency sub-band only. Cell edge band has no power restrictions and is orthogonal among the neighbouring cells, thus reducing inter-cell interference among cell-edge users. On the other hand, the remaining $2/3$ frequency sub-band for each cell can be used by the cell-centre users only and with limited power and is called the cell centre band. If the cell edge band is not occupied by data of the cell edge users, it can still be used by the cell centre users. This scheme is called soft frequency reuse as the frequency partition only applies to the cell edge users, whilst the effective frequency reuse factor is still close to one.

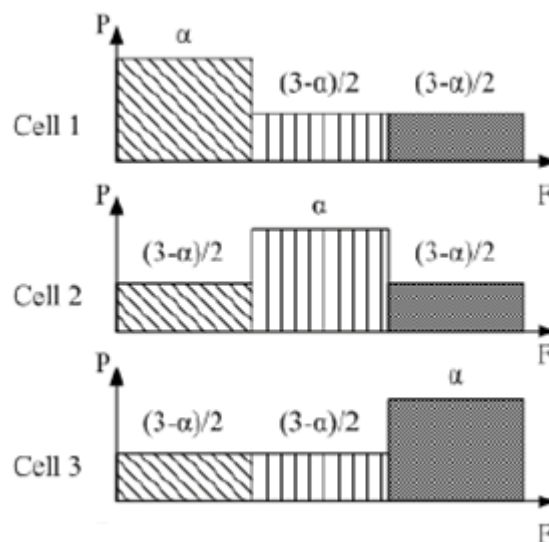

Figure 2-10: Frequency resources allocation for a soft-FFR scheme [22]

- Hard (or partial) frequency reuse. The whole frequency band is partitioned into two parts, the cell centre band, with reuse factor 1, and the cell edge band, with reuse factor 3. The cell-edge band is consequently divided into three orthogonal subbands, and each subband is allocated exclusively to one sector or cell in the cluster. The restrictions of frequency access for the cell centre/edge users are the same as for the soft reuse scheme. The cell edge users are only allowed to use the cell edge band, while the cell centre users are allowed to access both the cell centre and edge band, but with lower

priority than the edge users. The difference with the soft reuse scheme is that in soft reuse scheme the whole spectrum is used in each cell, while with the hard reuse scheme only the allocated cell edge subband can be used in addition to the common cell centre band.

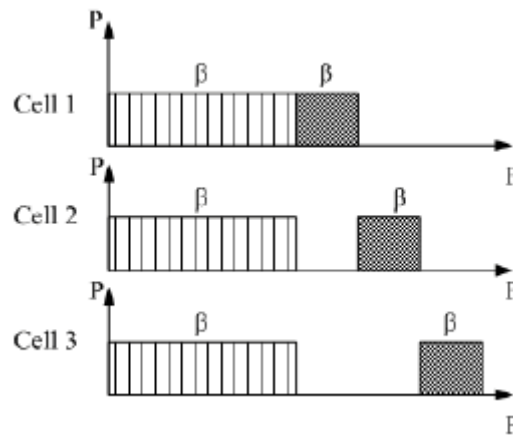

Figure 2-11: Frequency resources allocation for a hard-FFR scheme [22]

In both cases, resources are dynamically allocated to users, which must be classified into cell-edge users and cell-centre users. With this purpose, different information can be used, such as positioning information, received signal strength or link quality. Link quality information (CQI, Channel Quality Indicator) is widely used as this information is already available in the system as it is used for other RRM procedures such as power control and handover.

Nevertheless, these schemes are not completely efficient as only a small fraction of the spectrum is available in cell-edge regions, which can potentially have a large number of users resulting in unavailability of resources in the cell-edge region. In order to solve this problem dynamic interference coordination schemes arise. In these schemes cell-edge users are allocated the channel with lower level of interference according to the closest neighbour cell, providing higher resource availability on cell-edge region. Availability of positioning information becomes more important for the implementation of interference coordination schemes.

2.6.2 Interference coordination in an OFDMA system

In order to achieve a frequency reuse factor approximated to 1 and to solve the problem of degraded throughput and QoS on cell-edge, an interference coordination scheme in an OFDMA system is proposed. The proposal consists of an interference-based network planning scheme through the use of different frequency patterns by the users of a certain cell. In each cell a dedicated subset of frequency patterns are set to concentrate the interference, thus reducing the interference level on the rest of patterns. With this purpose, it is necessary to have further information about terminal's location as it is necessary to know, besides if the terminal is in the cell-centre region or the cell-edge region, which one is the closest neighbouring cell.

In order to present an example of interference coordination, an OFDMA tri-sector cellular system without synchronization between base stations is considered. Therefore, it is not possible to coordinate interference in the time dimension, but in the frequency dimension. With this purpose, OFDM spectrum carriers are grouped into frequency patterns. Each pattern consists of 11 groups of 4 carriers (44 carriers) where the spreading over 11 blocks takes care that the frequency diversity is sufficiently exploited. This allows 16 of these frequency patterns in an OFDM symbol since $16 \times 44 = 704$

subcarriers further it also contains place holders to put pilot carriers in. These frequency patterns (FP) are managed by the Radio Resource Management (RRM) and are assigned to the users by the base station scheduler.

The whole frequency band or set of all frequency patterns is partitioned into R disjoint subsets F_1, F_2, \dots, F_R . These subsets may contain frequency diverse frequency patterns to be robust against a frequency selective fading channel. The number of subsets R can be $R = 7$ or $R = 9$ for example. For simplicity they are depicted as blocks over the frequency axis as given in Figure 2-12.

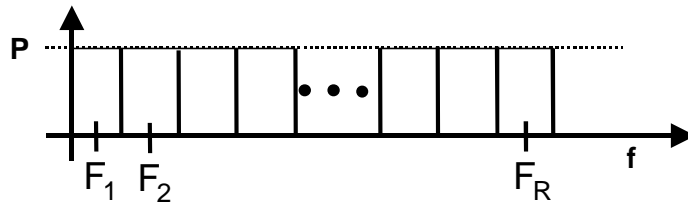

Figure 2-12: Partition of OFDM spectrum in R disjoint subsets F_n [38]

For that in each cell some frequency patterns can only be used with reduced power (soft approach) or are completely inhibited (hard approach). So in cell C_n the power of the subset F_n corresponding to the cell number is limited. In Figure 2-13 the proposed frequency planning for a tri-sector network with reuse factor $R=9$ is shown. For simplified denotation the cell C_n is just marked \bar{n} . This way, a cell is surrounded by neighbour cells with different cell number (which could be achieved also with $R=7$). As it can be observed, frequency patterns allocated to cell-edge terminals are directly related to the terminal location and specifically with the closest neighbouring cell.

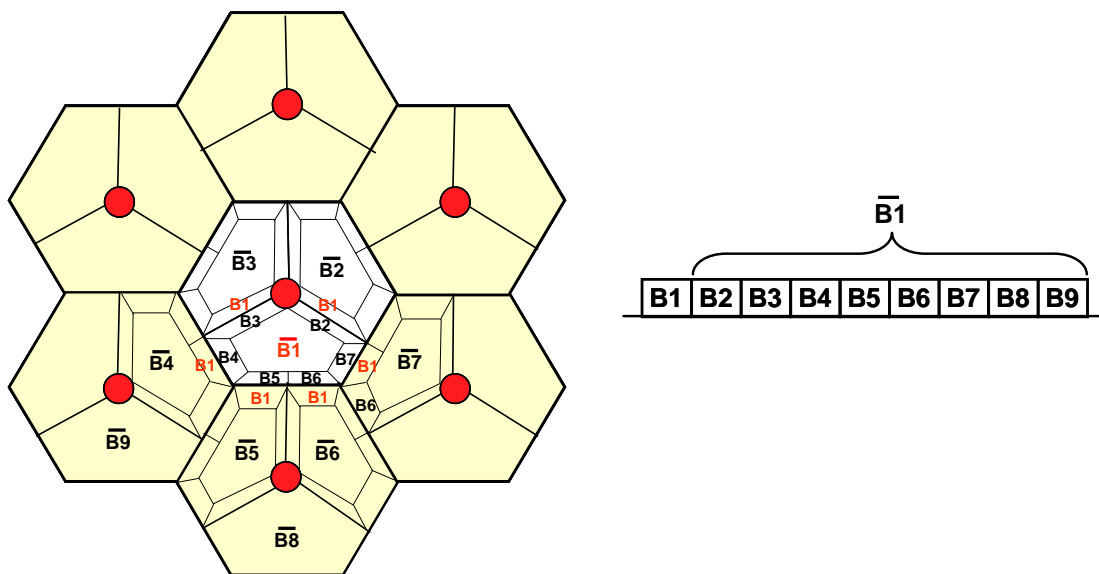

Figure 2-13: Frequency planning in an interference coordination scheme

The subset F_n is now used by terminals in neighbour cells approaching C_n from the outside. So for example in Figure 2-14 if a terminal approaches the border region to another cell \bar{k} it gets allocated frequency patterns from subset F_k where this other cell can not disturb much due to its power

limitation in F_k . For example if terminal T_1 approaches cell $\bar{1}$ as depicted by the green arrow it gets allocated frequency patterns from subset F_1 . So all terminals approaching cell $\bar{1}$ from the outside get allocated frequency block F_1 by their respective serving base station as long as they are in the border region and before a handover has to take place (this is marked by red numbers in the Figure 2-14).

Concerning the uplink, interference coordination works in a similar way. Interference from the outside terminals close to the edge of cell $\bar{1}$ is concentrated on frequency block F_1 that inside cell $\bar{1}$ can only be used by terminals near to the antenna, which can tolerate interference coming from outside terminals to a considerable extent. This removes the interference on all other subsets F_2, F_3 to F_9 of cell $\bar{1}$ which can now be used in cell $\bar{1}$ uplink with improved SIR. Therefore, the aim of resource allocation in the uplink is to concentrate the interference in a specific frequency pattern subset.

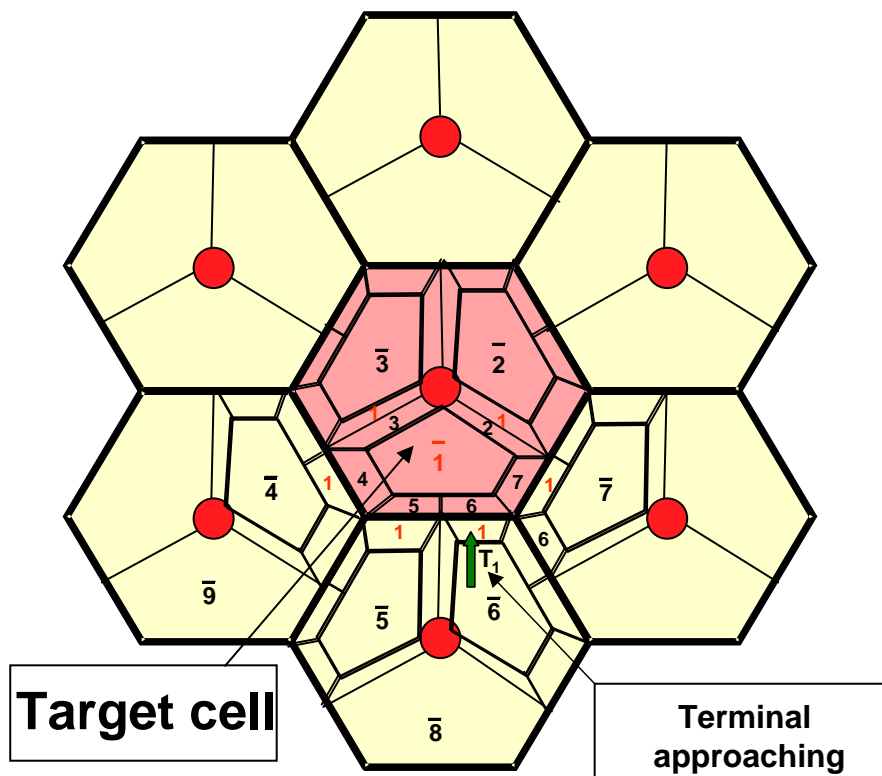

Figure 2-14: Frequency pattern allocation for a terminal approaching cell-border [38]

As can be seen from Figure 2-14 if the strips at cell borders to the other cells are marked with the allocated frequency block number, in the border region inside cell $\bar{1}$ six subsets (2 to 7) are used. So as a result here in 6/9 of the spectrum the interference is reduced so that the SIR is strongly improved. This yields higher throughput and improved QoS. It allows serving of the user even if it enters further in the neighbour cell or if it experiences further worsened radio conditions. Furthermore, all the frequency patterns are uniformly used over the cell cluster area, leading to an almost optimum use of resources for uniformly distributed terminals.

2.6.3 Advantages of interference coordination

With the proposed uplink interference coordination all frequencies are unaffected in the inner circle. Restrictions by network planning and coordination only take place in the border regions where the

availability of the frequencies is only slightly reduced (e.g. 6/7 or 6/9) compared to classic frequency reuse schemes where availability is massively reduced (e.g. 1/7 or 1/9) in all the cell area. Compared to FFR solutions, where only a few patterns can be used by terminals in the border regions, this solution presents a higher spectral efficiency. On the other hand, compared to a CDMA system, where this kind of interference coordination is not possible as codes in reception are not orthogonal due to multipath and lack of synchronization, this solution promises higher SIR and throughput at the cell-edge with a minimum loss of efficiency.

The allocation of a specific frequency pattern subset to the cell-edge region limits the availability of uplink frequency subsets for terminals in that region. This can be alleviated by extending the given solution to distribute frequency subsets between cell regions on demand under observation of the interference influence. So if e.g. all terminals gather at the border between two cells, a higher number of frequency pattern subsets can be allocated to the terminals in that region, inhibiting or restricting their use in the neighbouring cell. So also in this case the interference can be coordinated to improve the SIR or throughput.

So the technique can be considered as some kind of interference power planning. This is illustrated in Figure 2-15 where the interference burden in the uplink of e.g. cell $\bar{1}$ is depicted. If there would be no interference coordination the uplink usage of frequency patterns would be evenly distributed and all frequency subsets F_1 to F_9 would be evenly burdened by interference (measured at base station of cell $\bar{1}$ antenna) as shown by the green dotted line. Now if interference coordination would be ideal, the interference in F_1 is highly increased and the interference in F_2 to F_9 is strongly decreased as given by the red dotted curve.

In the realistic case there is still interference coming from neighbour cells. For example terminals using subset F_6 in cell $\bar{7}$ at the border to $\bar{6}$ still make interference in cell $\bar{1}$ on F_6 . Further the location or signal strength measurements used to detect when the terminals enter a certain region will not be ideal. So the realistic case is depicted as black line in the figure. That means the interference in F_2 to F_9 is not ideally reduced but still when looking at the black line it is considerably reduced compared to the case of no interference coordination. This reduction of interference gives an improved SIR which leads to higher uplink throughput especially at the cell edge.

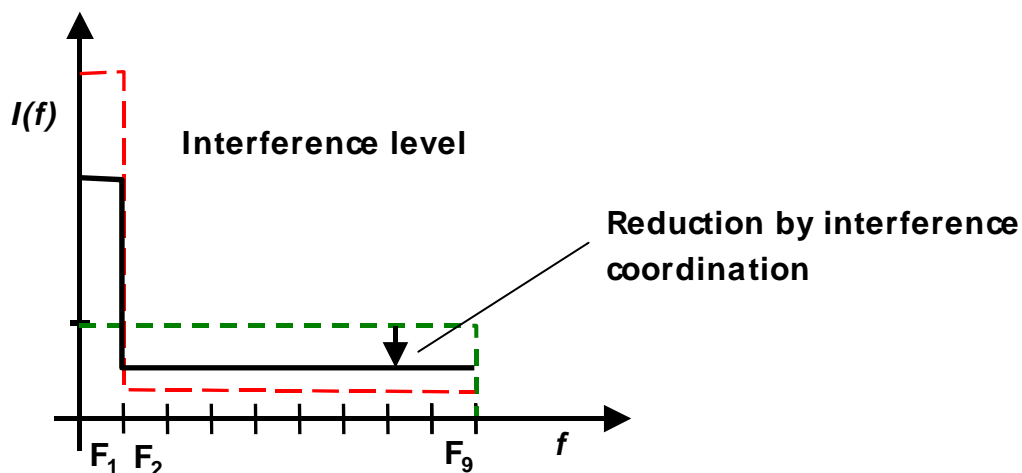

Figure 2-15: Distribution of interference power over the F_n frequency pattern subsets [38]

2.6.4 Use of location information

The implementation of interference coordination scheme requires the availability of accurate information concerning users' location in order to classify them into the different regions that are planned. This information can be retrieved through positioning systems or estimated from interference measurements.

- In case of localization systems, position can be retrieved from external systems such as GPS or indoor positioning systems (e.g. UWB), or be implemented in the cellular network itself based on the estimation of parameters related to received power (RSSI) or time of arrival (TOA, TDOA) measured on specific pilots for each base station. Based on these estimations, trilateration or more advanced algorithms can be applied to obtain users' position. Concerning mobile network operators, these networks must include positioning systems, whether integrated on terminals (GPS) or implemented in the network itself, for users' localization in emergency calls, so in this case location information would be already available.

- In case of interference measurement specific pilots are used for each cell. Each terminal reports back to its serving base station which other base stations are strongly received and which is the strongest. This is known from classical handover algorithms and does not require additional signalling to be introduced. It is just necessary that the base station number identifies the inhibited frequency subset. The terminal is then scheduled on the inhibited subset of that strongest interfering base station. For the uplink the scheme is a little more complex, as the base stations should measure from which cell and on which frequency patterns the interference comes and with what strength and signalling would be required to inform to the serving base station. An easier approach for the uplink is based on the approximation that uplink interference generation is reciprocal to downlink interference measurement. Then the base station would use the same information provided by the terminal for the downlink to apply the same restrictions on the uplink, thus avoiding the signalling between the base stations.

The main advantages of using positioning information for interference coordination instead of received signal strength levels are:

- Reduced power consumption in the terminals
- Reduced signalling load
- Lower complexity of allocation algorithms
- Higher immunity to fading or presence of obstacles

2.6.5 State of art and examples in literature

On this section several proposals raised within the standardization processes of IEEE 802.16 and 3GPP LTE are presented, as well as some works found in the literature that propose the use of location information in resource allocation and interference management in order to maximize spectral efficiency.

Concerning IEEE 802.16 (WiMAX) system, based on the characteristic of IEEE 802.16e (mobile WiMAX) [23] frame structure, and specifically on the possibility of subchannel segmentation and permutation, the implementation of FFR schemes was proposed [24], and their performance has been evaluated in various works [25][26].

In the standardization process of WiMAX advanced radio interface, IEEE 802.16m, the use of both hard and soft FFR schemes is considered, as it is proposed in multiple contributions [27]-[30]. The use of FFR schemes is also considered on the IEEE 802.20 system [31].

Within the standardization process of 3GPP LTE with regard to the evolved radio access, E-UTRA, several manufacturers have contributed with different proposals to mitigate the problem of cell-edge degradation in OFDMA systems with a reuse of 1 based on interference planning and coordination. In general, all of them are based on the Fractional Frequency Reuse concept and the use of different reuse factors on the cell-centre region and the cell-border region. For example, Siemens proposes in [32] the use of a hard FFR scheme for the uplink. Ericsson also opts for the use of FFR schemes in [33].

On the other hand Huawei proposes in [34] the use of a soft frequency reuse scheme, where the spectrum available on each cell is divided into two groups, the minor subcarrier group, which has a limited power and can only be used in the cell-centre region, and the major subcarrier group, which can be used in the whole cell with no power restriction and has a reuse factor of 3. Nokia also proposes the use of soft frequency reuse schemes in [35].

In [36] LG proposes the use of a resource allocation scheme based on priorities. In each sector the available resources are organised according to some previously defined priorities, which are different in each sector. Users transmitting with high power level, which will be distant from the cell centre and therefore more sensitive to ICI, are allocated high priority resources. These high priority resources will be low priority resources in the adjacent sectors and therefore will be used by users close to the antenna transmitting with low power and consequently causing low interference.

Finally, the most advanced scheme is the one proposed by Alcatel in [37]-[38], based in interference coordination and that we have previously presented in detail.

In [39] a frequency planning and resource allocation scheme called Universal Frequency Reuse (UFR) is proposed and subsequently enhanced with the use of location information. UFR scheme assigns the whole frequency resource to all cells, so that the whole resource could be reused without any restrictions in all the cells as in the cellular systems with frequency reuse factor of 1. Then, it defines a cell-specific resource allocation rule for each cell, so as to control mutual interferences among neighbouring cells in a cooperative way. The resource allocation rules are designed so that they can avoid maximally inter-cell interference (ICI) when the loading factor is less than a threshold loading factor, while exceeding the threshold, ICI would be averaged over the whole frequency resource. Hence, the proposed system can maintain ICI always at the minimum level, in turn expecting greater spectrum reuse efficiency.

Each cell in the proposed system allocates the resource unit according to a cell-specific resource allocation rule, that is, the starting point of subchannel assignment is different on each cell. For example, three different allocation rules can be defined and consequently cells would be grouped into 3 different reuse sets. Therefore, if loading factor is under certain threshold co-channel interference between adjacent cells is avoided. Even when the loading factor increases and neighbouring cells interfere with each other, the ICI levels might not be abrupt, but instead, are averaged, thus making the ICI levels gradually increasing. Note that one cell can use the whole frequency resource as in an FRF=1 system when neighbouring cells are very lightly loaded. Therefore, for high load levels UFR behaves as a scheme with reuse of 1 providing high spectral efficiency, while for light load levels UFR behaves as a scheme with reuse of 3 minimizing co-channel interference.

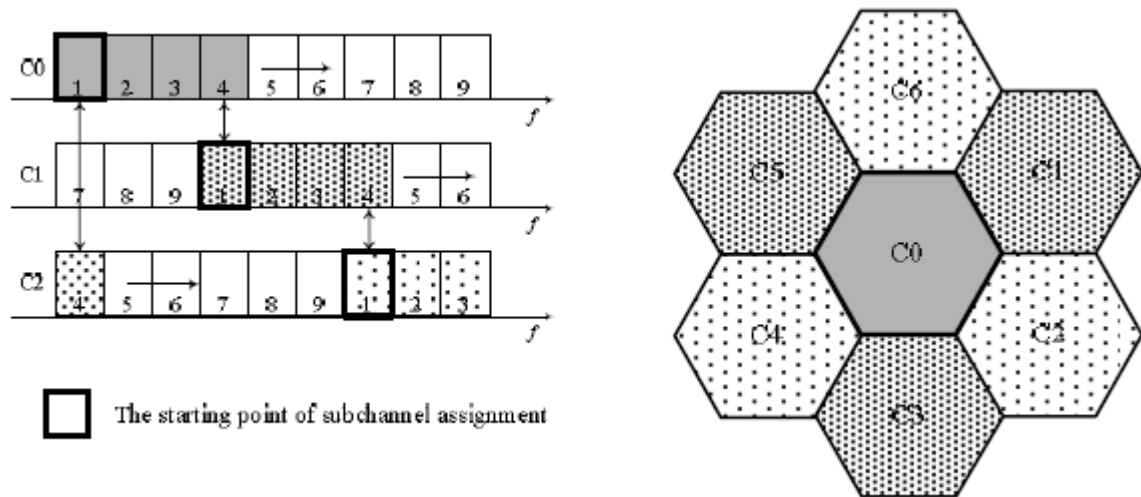

Figure 2-16: Subchannel allocation scheme in a UFR system at cell level [39]

In case the loading factor is less than or equal to $1/3$, the proposed system could minimize extremely the ICI level by dividing the cells in each reuse set into two groups, and then applying two staggered patterns for respective groups, i.e. using reverse order in resource allocation. In this case, if the signalling load is lower than $1/3$, not only the ICI between cells of different reuse sets is reduced, but also between cells within the same reuse set but different allocation pattern (group). Under a loading factor less than $1/6$, the interference between cells with different allocation pattern (group) is completely avoided, thus increasing the reuse distance by a factor 2 and significantly reducing the ICI level.

Moreover, a modified version of UFR system using position information of a user within a cell is proposed. A given frequency resource is divided into three reuse frequency bands and hexagonal cells are divided into six triangle sub-cells. Then, three reuse patterns with two reuse frequency bands each and designated by C1, C2, and C3 are defined and assigned to cell C1, C2, and C3, respectively. Finally, each cell allocates one reuse frequency band to three sub-cell regions and the other reuse frequency band to the other three sub-cell regions. This way, the frequency reuse band allocated to each sub-cell region is different from the frequency reuse bands allocated to the adjacent regions. Using the above mentioned resource mapping rule, each user can avoid always ICI from the nearest interfering BS.

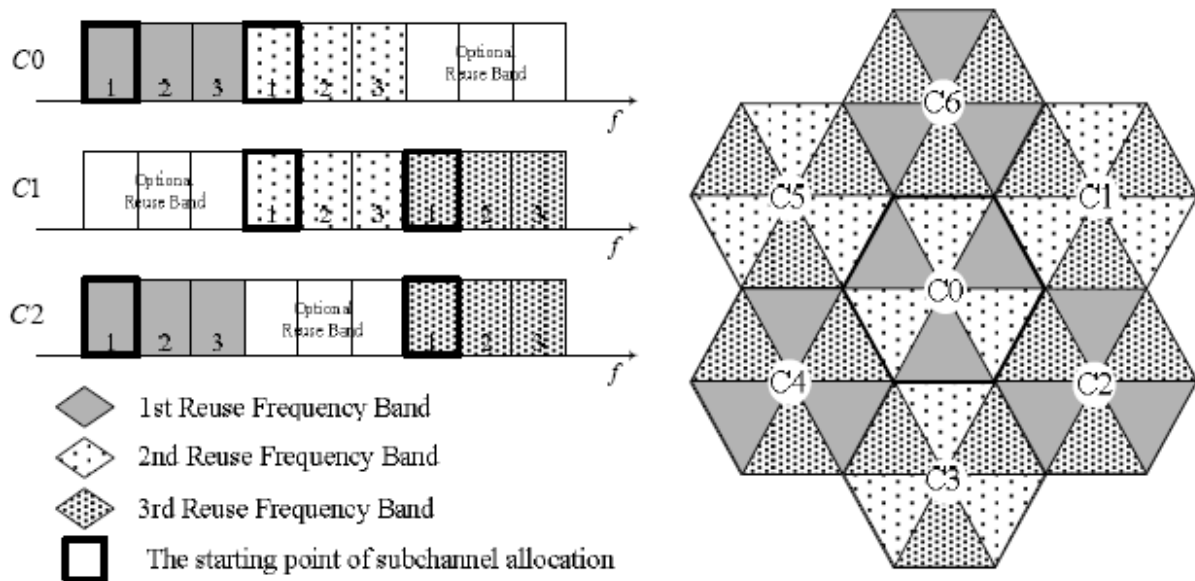

Figure 2-17: Subchannel allocation scheme in a modified UFR system with position information [39]

Although the proposed scheme could be implemented using CQI (Channel Quality Indicator) estimations in order to identify which is the closest base station, the use of positioning information reduces the complexity, signalling load and power consumption due to CQI measurement. The proposed system can also reuse the optional reuse band when the ICI levels into the optional band from neighbouring cells are less than a certain threshold and/or using a very low power level not so as to disturb the geometric ICI condition into neighbouring cells. Also using the modified UFR system, the ICI level can be further reduced when the loading factor is less than or equal to half the full 1st reuse frequency band, if two staggered resource allocation patterns are defined for each reuse frequency band.

Finally, concerning dynamic interference coordination schemes, in [40] the improvement in the reuse factor given the knowledge of the mobiles' locations is evaluated in a generic cellular network. Positioning information is used to develop an interference-adaptation dynamic channel allocation (DCA).

In fixed channel allocation (FCA), a channel assigned to a cell can be reused according to some fixed cell reuse pattern. FCA suffers from inefficient use of the radio spectrum. To correct this limitation of FCA, dynamic channel allocation (DCA) schemes have been proposed. The traffic adaptation-based DCA schemes rely on the idea that instead of dedicating the channels to cells, channels are placed in a pool and allocated on demand to the cells based on some allocation rules. Reuse of previously allocated channels is governed by the same minimal distance rule. In both FCA and the traffic-adaptation DCA, the channels are usually allocated to cells based on the assumption that a mobile may be located anywhere within the boundary of that cell. Thus, a channel is allocated to a cell, rather than to a mobile. These schemes suffer from the fact that the fixed reusability factor may be too pessimistic; e.g., mobiles that are close to their base stations may not interfere with each other even if they are in adjacent cells. In the interference-adaptation DCA schemes, mobiles measure the amount of interference that they receive on different channels to determine the usability of a channel. Therefore, the allocation of channels is to mobiles rather than to cells. According to mobile's

positions, a channel may be reused provided that the potential interference caused by the user is under a certain threshold.

Through simulations, it is shown that using the proposed strategy the total number of channels required to serve a given mobile population is reduced by nearly a factor of two. Nevertheless, the implementation of this kind of strategies requires high complexity resource allocation algorithms and high signalling load between the base stations, so they have no further application in real systems.

3 Location-Awareness in Wireless Ad-Hoc Networks

In this contribution the influence of the location awareness on the performance of multi-hop wireless communication systems lacking any pre-defined infrastructure is investigated. Advantages and disadvantages of utilizing the knowledge of network topology, either global or local, are characterized by means of computational simulations and a mathematical framework resorting to statistical analysis. And yet previous outcomes obtained in correlated tasks within the context of WP4 provide valuable insights for future studies.

In fact, during the activities related to Task 4.4 the aftermaths of utilizing the relative positions of neighbour nodes to conduct network routing were addressed. An analytical framework relying on statistical examination is used to identify the benefits of such hopping strategies to the operation of ad hoc networks. The transport capacity and a novel metric coined *Multi-hop Aggregate Information Efficiency* (MIE_A) are used as figures of metric to characterize the network performance. It is anticipated that based on the established framework, adequate strategies taking advantage of the location information can be derived and appropriately evaluated.

Additionally, contention-based geographic forwarding schemes to perform random multiple access and network routing have been investigated in the scope of Task 4.2. A promising technique based on auction theory and exploiting location information to support the operation of network entities was devised. In Task 4.5, the preliminary evaluation scenarios will be extended and the impact on the overall network performance will be assessed by means of system-level simulations.

3.1 Impact of location information on the network capacity

During the activities related to Task 4.4 (presented in D.4.4.1), theoretical studies regarding the effects of a macro routing policy based on the relative position amongst the nodes in the network, namely hopping strategy, have been addressed. Specifically, the impact of the hopping strategy was evaluated using the Transmission Capacity (TmC) metric [41] for an ad hoc network.

In addition to the studies based on TmC, a novel analytical framework called *Multi-hop Aggregate Information Efficiency* (MIE_A) was proposed. The main difference between MIE_A and TmC is that the later is not able to characterize the spatial evolution of a packet in both single-hop and multi-hop links, while the first captures the effects of the number of hops and the distance through the packet trajectory.

In this section, the MIE_A formulation together with preliminary results will be presented. These results can be used as a guideline to design new strategies (either cognitive or deterministic) based on the location awareness.

3.1.1 Multi-hop Aggregate Information Efficiency

The *Multi-hop Aggregate Information Efficiency* is performance figure proposed to characterize the statistical behaviour of multi-hop wireless networks as a whole. The MIE_A can be mathematically expressed as

$$MIE_A = d_{rd} \times (1 - P_{mb}) \times s_{mh} \times \rho_{at} \times (1 - P_{out}), \quad (1)$$

where \bar{d}_{rd} is the average distance from all source-destination pairs, P_{mh} and ϵ_{mh} are respectively the packet loss probability and the spectral efficiency in multi-hop links, ρ_{act} is the average density of active links in the network and P_{out} is the average link outage probability.

The main idea behind the MIE_{Δ} formulation is to characterize the packet progress (bits-meters) temporal-spectral-spatial efficiency (second-hertz-meter square) in multi-hop networks. Indeed, this framework can be applied in both information-theoretical (more general and fewer assumptions) and practical approaches (specific transmission techniques). For instance, preliminary results addressing IR-UWB ad hoc networks were presented in the D4.4.1.

Next, an example of the MIE_{Δ} framework is presented in order to evaluate how the smart use of the location information can increase the network efficiency.

3.1.2 Network modelling

The same network model used in the D.4.4.1 is analyzed. The network consists in toroidal square area with nodes following a 2-dimensional Point Poisson Process (PPP) [42], divided in 2 sets: potential receivers (willing to receive) and potential transmitters (wishing to transmit). Handling the proprieties of PPPs, the fundamental network behavioural variables can be statistically defined in close-form, approximation or upper/lower bound equations. For convenience, the details of their analytical derivation are suppressed in this deliverable¹.

3.1.3 Distance characterization

In a 2-dimensional toroidal square, any node of the network can be analyzed as its centre. Let L be the length of the square side. Remembering that the nodes in a PPP are uniformly placed in the area, the average source-destination distance \bar{d}_{rd} of a multi-hop link can be computed as

$$\bar{d}_{rd} = \int_{-L/2}^{L/2} \int_{-L/2}^{L/2} \sqrt{x^2 + y^2} dx dy = 0.3826 \times L. \quad (2)$$

In addition to \bar{d}_{rd} which is a pure topological parameter, the transmitter-receiver distance in a single-hop must be characterized in terms of both the density and hopping strategy. The hopping strategies used here are furthest-, closest- and random-neighbour. The definition of the node neighbourhood depends on the transmission range \bar{d} (physical parameter related to the minimum power that a node can decode a packet). The probability density functions (pdf) of the distance are listed for the furthest-, closest- and random-neighbour hopping strategies [43][44]:

$$f_F(d^*) = 2 \pi d^* \rho_r \cdot \frac{\exp(-\rho_r \pi d^{*2})}{\exp(-\rho_r \pi d^{*2}) - 1}, \quad (3)$$

$$f_C(d^*) = 2 \pi d^* \rho_r \cdot \frac{\exp(-\rho_r \pi d^{*2})}{\Gamma(\rho_r \pi d^{*2} + 1)}, \quad (4)$$

$$f_R(d^*) = \frac{2 d^*}{L^2}, \quad (5)$$

where ρ_r is the density of potential receivers.

¹ The detailed derivation of the equations can be found in the D.4.4.1.

3.1.4 Active links

The formation of the links follows an autonomic procedure described as follows:

1. The potential transmitters discover their neighbourhood, i.e. the potential receivers inside the transmission range d of each transmitter. Notice that some transmitters and receivers can be isolated.
2. The transmitters select in their neighbourhood the receiver pair following the hopping strategy;
3. If more than one transmitter is associated with a given receiver, the later will choose randomly its transmitter pair.

In order to compute the density of active links, the Slivnyak's theorem [42] is invoked. Assuming independence between the receiver choices, the density of active links can be approximated independently of the hopping strategy as

$$\rho_{\text{AL}} = \rho_r \times \left(1 - \exp \left[\frac{\rho_t}{\rho_r} (\exp[-\rho_r \pi d^2] - 1) \right] \right), \quad (6)$$

where ρ_t is the density of potential transmitters.

3.1.5 Outage probability

A lower bound of the outage probability ($\text{SIR} < \text{SIR}_{\text{th}}$) based on the distance-dependent path-loss with exponent α is used. The idea of the lower bound is to consider the outages events related to the dominant interferer [41].

In an information theoretic sense, the SIR_{th} is referred to a minimum transmission rate ϵ (in bit per hertz-second) possible to be achieved with vanishing error probability for each one of active links. Assuming the noise negligible and interference as a Gaussian distribution, the SIR_{th} can be computed using the Shannon capacity formula as

$$\text{SIR}_{\text{th}} = 2^\epsilon - 1. \quad (7)$$

Using the SIR_{th} and considering the complementary probability of the existence of a dominant interferer, a lower bound for the outage probability can be computed for the furthest-, closest-, random-neighbour hopping strategies as

$$P_{\text{F,out}} \geq 1 - \rho_r \cdot \frac{1 - \exp(-(\rho_{\text{SI}} \text{SIR}_{\text{th}}^{2/\alpha} - \rho_r) \pi d^{2\alpha})}{(\rho_{\text{SI}} \text{SIR}_{\text{th}}^{2/\alpha} - \rho_r) \times (\exp(\rho_r \pi d^{2\alpha}) - 1)}, \quad (8)$$

$$P_{\text{C,out}} \geq 1 - \rho_r \cdot \frac{1 - \exp(-(\rho_{\text{SI}} \text{SIR}_{\text{th}}^{2/\alpha} + \rho_r) \pi d^{2\alpha})}{(\rho_{\text{SI}} \text{SIR}_{\text{th}}^{2/\alpha} + \rho_r) \times (\exp(\rho_r \pi d^{2\alpha}) - 1)} \quad (9)$$

$$P_{\text{R,out}} \geq 1 - \frac{1 - \exp(-\rho_{\text{SI}} \text{SIR}_{\text{th}}^{2/\alpha} \pi d^{2\alpha})}{\rho_{\text{SI}} \text{SIR}_{\text{th}}^{2/\alpha} \pi d^{2\alpha}}, \quad (10)$$

3.1.6 Multi-hop parameters

Firstly, the packet error probability P_{mh} in a multi-hop link will be addressed. Assuming that a packet needs n_h hops to reach its destination node its source and the error event is independent in each single-hop link, P_{mh} can be computed as

$$P_{mh} = 1 - (1 - P_{sh})^{n_h}, \quad (11)$$

where P_{sh} is the packet error probability that depends on the modulation technique, code technology and retransmission policy².

Now, the transmission rate ϵ_{mh} over a multi-hop link will be analyzed. Defining transmission rate as the number of bits transmitted successfully per time and frequency, the rate ϵ_{mh} can be computed as the rate ϵ divided by the number of hops (number of times that a packet need to use network resources). Mathematically,

$$\epsilon_{mh} = \frac{\epsilon}{n_h}. \quad (12)$$

However, the typical number of hops n_h in an ad hoc network depends on several factors, including the routing mechanism, the application, etc. For simplicity, an optimistic estimate is

$$n_h = \frac{d_{sd}}{d_{tr}}, \quad (13)$$

where d_{tr} is the single-hop average distance, computed taking the expected value of the distance pdf presented in (3), (4) and (5).

In average terms, this represents an ideal hopping pattern where the average source-to-destination distance d_{sd} is travelled in a straight line and in leaps of d_{tr} , which is the average single-hop distance of the network. In other words, this implies an assumption that the routes from sources to destinations have negligible deviation.

3.1.7 Preliminary results

The results presented in this section are addressing how the use of the location information can affect the overall performance of the network. Specifically, the effects of the hopping strategies and the definition of the neighbourhood into the multi-hop aggregate information efficiency are studied.

² Using the Shannon Formula presented (7), the bit error probability tends to 0.

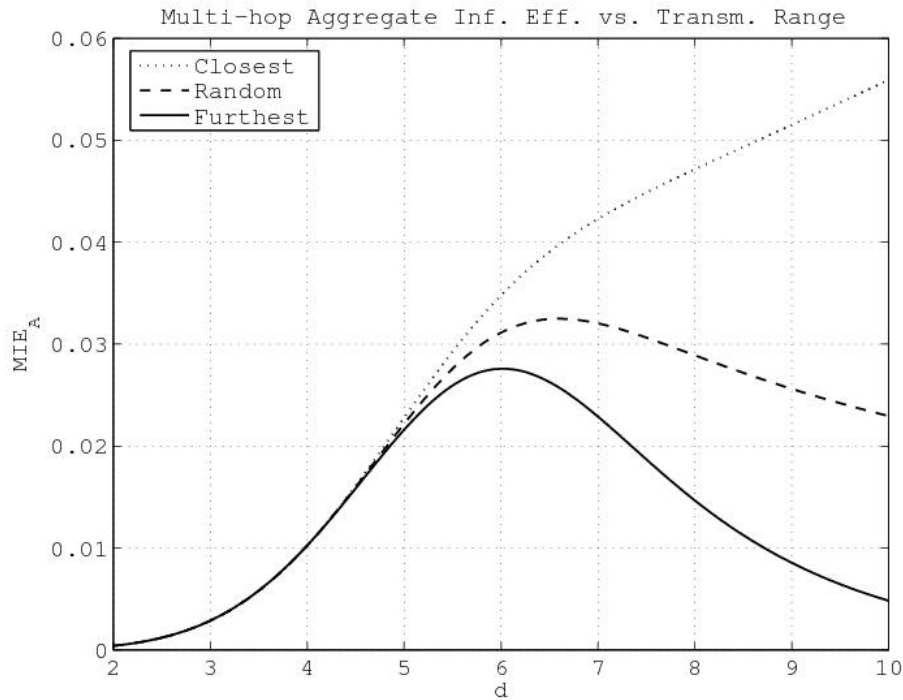

Figure 3-1: Multi-hop aggregate information efficiency vs. transmission range for different hopping strategies, and with $\rho_1 + \rho_2 = 0.02$, $\alpha = 4$, and $\varepsilon = 4$ bits/sec-Hz.

Figure 3-1 presents MIE_A as a function of the transmission range d for the furthest-, closest- and random-neighbour hopping strategies, node densities $\rho_1 = \rho_2 = 0.01$ path-loss exponent $\alpha = 4$, and rate $\varepsilon = 4$ bits/sec-Hz. One can observe that as the transmission range increases, the MIE_A has a peak for the furthest- and random- neighbour hopping strategies, while it continually increases adopting the closest-neighbour strategy. With the given density, smaller transmission ranges imply that the network is not interference limited. As the transmission range increases, the density of active links increases, bringing up the amount of interference experienced at all links. With the most “conservative” (closest-neighbour) hopping strategy, however, the effect of the increasing interference is less impacting, and consequently the overall performance continues to increase up to larger d 's.

3.2 Position-centric Strategies for Autonomous Multi-Hop Networks

This contribution investigates the utilization of location information to augment the operation of medium access control schemes and network routing solutions in infrastructureless networks. The local knowledge of network topology is used to influence the operation of network functionalities, and so doing improve the management of network resources overall.

A mathematical framework resorting to stochastic geometry and probability generating functions was initially used to identify the benefits and shortcomings of using location awareness. Computer simulations were also used to corroborate results of the mathematical modelling and extend the investigations by considering more realistic deployment scenarios. A system-level event-driven simulator has been implemented in C++ OOP language for evaluate the impact of location information on the performance of ad networks.

In ad hoc communication systems with no pre-defined infrastructure, nodes inevitably resort to multi-hop links to reach destinations farther than their own transmission ranges. The operation in such distributed deployments without any explicit centralized coordination may benefit substantially from side information, for example, interference levels, residual energy and location information, so as to lead the decision of autonomous network entities.

Preliminary results have shown that location information significantly improves the system performance. For instance, contention-based geographic forwarding strategies combining Relay Selection Algorithms (RSAs) and geographic forwarding schemes in a cross-layer approach are addressed in [49], [50], [51]. It is shown that using the location information to ponder the routing decisions increases significantly the packet delivery success ratio. And the location information is effectively used not only to improve the contention avoidance and resolution stages of medium access control, but also routing procedure.

The preliminary investigations were carried out using a simplified network model in homogeneous deployment scenarios without explicitly addressing the interference problem. For the forthcoming investigations, more elaborated scenarios taking into consideration distinct interference patterns and node characteristics are envisaged. However, the preliminary investigations provided insightful guidelines to extend the studies. Computational simulations will be used to characterize the impact of location awareness on the performance of such ad hoc networks.

In the following sections, we perform initial investigations about the impact of location awareness on the performance of the ad hoc network. Final observations and perspectives are provided in Section 3.3.

3.2.1 Preliminary Evaluation

In this section we review a preliminary assessment of ad hoc networks benefiting from location information to conduct routine network functionalities. Local knowledge of topology is used to enhance the operation of random multiple access schemes and relay selection algorithms. Indeed, It is observed that the routing protocols relying on geographic forwarding strategies are favoured by the improved performance of the localized decisions at each hop along the chain of nodes. Following sections provide further details of the evaluation scenarios and the methodology employed to assess the applicability of proposed solutions.

3.2.2 System model

The investigations are driven in scenarios where nodes are randomly and uniformly distributed over the network area. All nodes operate independently following their own duty cycle. Even though no mobility is considered, the set of active nodes varies impacting on the network dynamics. The minimum node degree and corresponding radio range are set in order to guarantee network connectivity. Initial investigations are conducted considering a simplified two-state channel model where the medium access is either busy or idle. Nodes can only initiate transmission interactions when the air interface is idle. For the preliminary investigations, packet collisions are the only source of packet errors and the random access scheme is based on slotted ALOHA. Additionally, we have assumed nodes are not affected by the exposed and hidden terminal problems. A more realistic capture model, where packets are correctly received conditioned on fulfilling a reception threshold, is envisaged for the extension of the investigations. Moreover, simultaneous transmissions among

multiple sources and final destinations will be enabled, once that by now multiple sources can only transmit to a unique final destination (sink node) in the evaluation scenarios.

In such Random Multiple-Access (RMA) networks, essentially contention-based, nodes are continuously competing to access the shared channel. In such networks, contention-based channel access protocols are the natural choice (e.g. ALOHA, Carrier Sense Multiple Access (CSMA) and thereof variations) to control access to the air interface [45]. In this contribution we investigate two contention-based geographic forwarding strategies combining random access schemes with geographic forwarding procedures. A totally random relay selection approach based solely on the standard splitting tree algorithm for performing RMA communications, and an auction-based approach exploiting the local knowledge of network topology to avoid collisions are investigated [46]. The Contention Resolution Algorithms (CRAs) are classified in terms of the endured CRIs necessary to select the most suitable relay among the all the eligible neighbours. An underlying assumption is that all transmissions are slot-wise synchronized. It is worth emphasizing that only the time necessary to resolve the contentions is considered for the delay analysis of the CRAs. Neither the queuing time nor the retransmissions of packets are taken into consideration for the overhead assessment [47].

The STA scheme is based on the standard splitting tree algorithm for RMA communications and is implemented considering the conventional Blocked Access Protocol (BAP), which means that no relay is allowed in the transaction once the contention has been initiated [48]. Succinctly, the source node initiates the relay selection transaction by issuing a Request to Send (RTS) packet. Neighbour nodes that listen to the source's requisition split themselves randomly and independently based solely on a common probability that dictates the likelihood of accessing the shared medium. If the Clear To Send (CTS) packets of eligible relays collide, nodes that have transmitted in the previous slot decide to retransmit or to refrain tossing a Q-sided coin with fair probabilities. And yet the source node should receive the replies from all the candidate relays so as to select the next relay greedily – to select the closest node to the destination whether there is one available. Figure 3-2 illustrates the geographic decision region used in conjunction with the totally random relay selection approach.

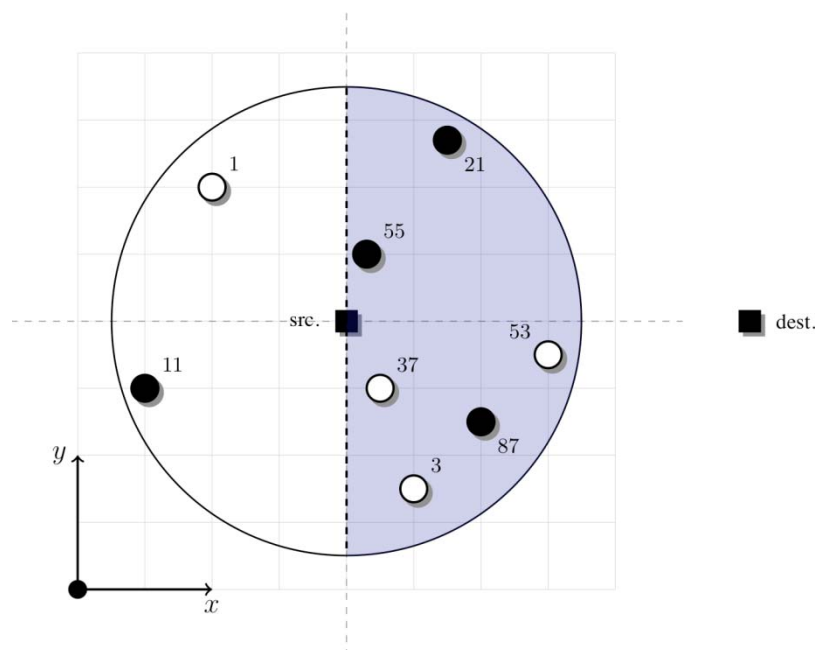

Figure 3-2: Sectoral decision region.

The auction-based RSA deals with the collision avoidance/resolution stages by employing economic game-theoretical concepts [52]. Typically, when a source node has a packet pending for transmission, an RTS/CTS handshake is triggered to avoid simultaneous transmissions [45]. However, each suitable relay dwelling on the source's radio range, which has received an RTS packet, replies with a CTS packet and collisions may occur. Thus, an appropriate mechanism has to be employed to cope with the imminent contention. In [49] Dutch auctions are proposed as an effective alternative to address the relay selection process in conjunction with random channel access solutions. In such transactions, source node plays the role of an "auctioneer" and potential relays are the "bidders". Indeed, Dutch auctions are extremely convenient to sell goods – assignment of network resources – quickly. The reasons are two-fold, the auction ends with the very first bid and the auctioneer may set accordingly the decreasing rate of the artifact value (depreciation rate) aiming at quickening the auction [52]. Figure 3-3 illustrates the convex lens decision region employed together with the auction-based solution.

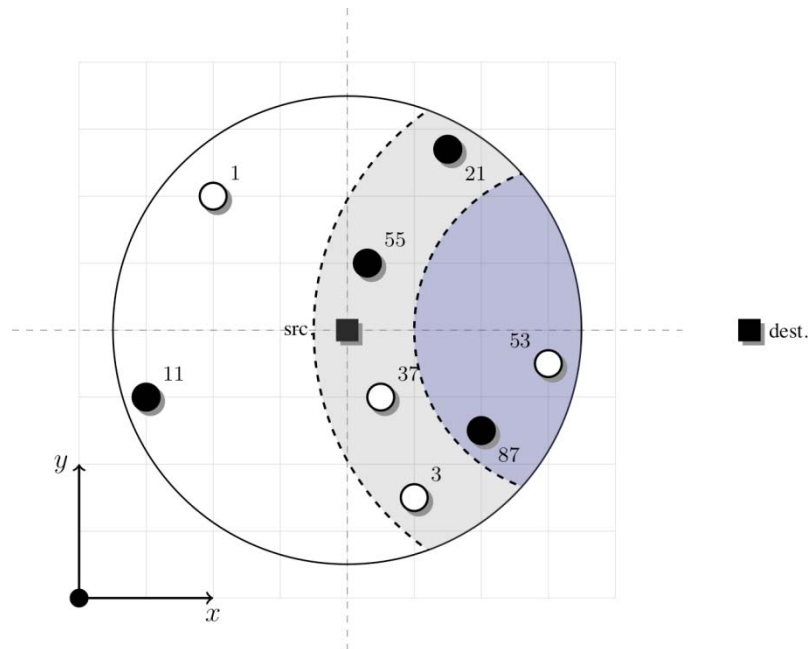

Figure 3-3: Convex lens decision regions.

Figure 3-4 and Figure 3-5 illustrate the routing trajectories in homogeneous deployment scenarios where nodes go asleep and awake following their own duty cycle. Specifically, Figure 3-4 regards one single source node, while Figure 3-5 shows multiples source nodes. We observe that multiple routing trajectories are established between the source node(s) and the sink node depending on network dynamics and availability of eligible relays.

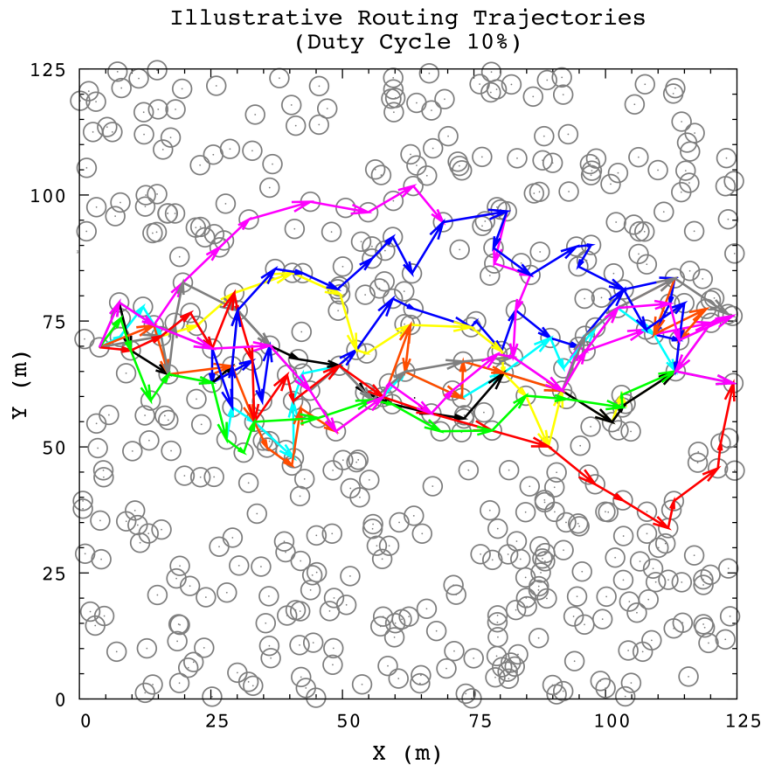

Figure 3-4: Illustration of routing trajectories when simulating a single source node.

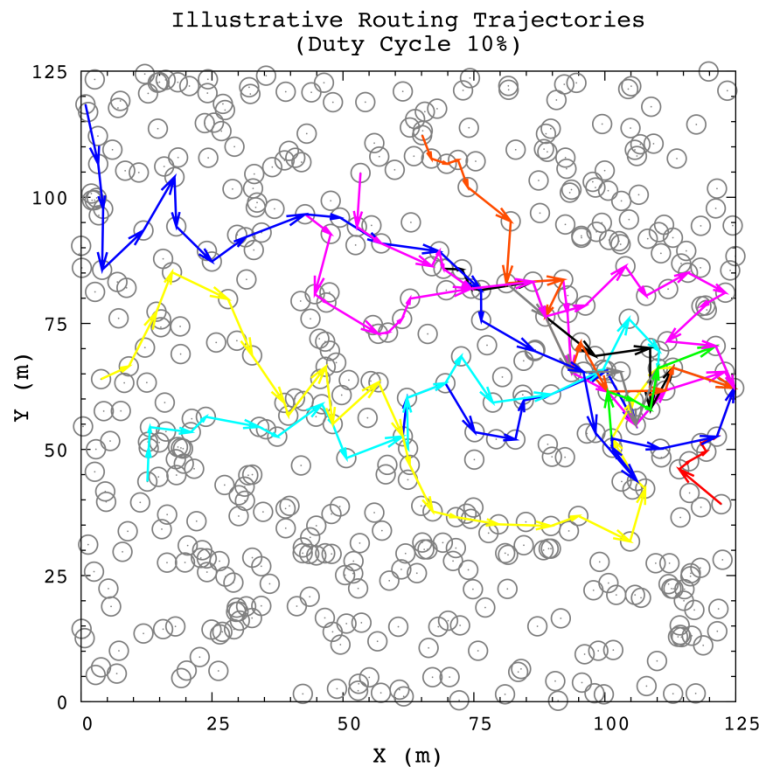

Figure 3-5: Illustration of routing trajectories when simulating multiple source nodes.

3.2.3 Preliminary Results

The results presented in this section were generated using the event-driven system-level simulator introduced in [53]. The MAC relay selection mechanism and the routing protocol are assessed via

computer simulations. A dynamic radio network simulator is used to evaluate the overall network performance and effectiveness of the solutions. The system-level simulator was implemented using C++ Object Oriented Programming (OOP) language and following event-driven paradigm. All simulations were performed using topologies generated randomly, with nodes uniformly distributed over an 125m-wide square (see Figure 3-5). The minimum node degree and corresponding radio range are set so as to guarantee the connectivity of the network. All nodes operate independently and traffic is Poisson-distributed, with adjustable packet inter-arrival time, assigned randomly to the nodes. The nodes' buffers have unitary length. The time a packet stays queued in a node's packet buffer, including the time the node sleeps, is added to the final delivery latency metric.

Figure 3-6 shows the percentage of data packets successfully received at the sink node for increasing values of packet delivery latency. In this figure a totally random relay selection algorithm is compared against the auction-based relay selection approach. As can be seen from this figure, the auction-based solution remarkably outperforms the totally random approach for both lower and higher network loads. Owing to the local knowledge of network topology, the auction-based solution provides substantial gains in terms of packet delivery latency. For instance, the delivery latency of the totally random approach is less than 20% of the maximum tolerable delay for only half of the realizations, while using location information more than 90% percent of the realization occur in less than 20% of the maximum allowed delay.

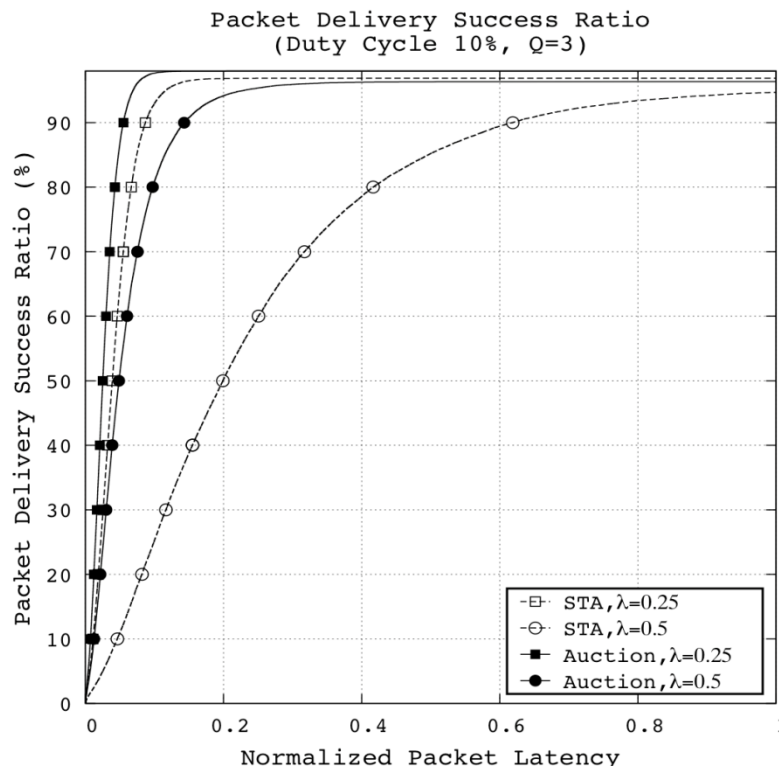

Figure 3-6: Packet delivery success ratio for the contention-based geographic forwarding strategies.

Figure 3-7 shows the distributions of the number of hops – in excess of what would take if packets were to be forwarded in a straight-line, with zero awaiting time (perfect relaying) – required by the routing protocols under the simulated conditions. When compared to the totally random approach, the solution exploiting location information presents shorter trajectories.

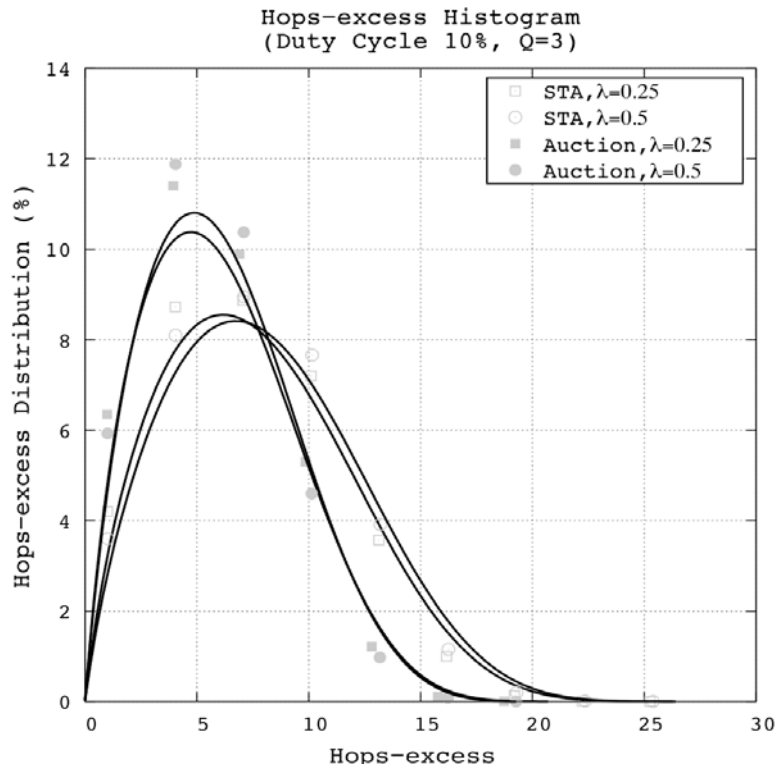

Figure 3-7: Hop-excess distributions for the contention-based geographic forwarding schemes.

3.3 Final Remarks and Perspectives

The results of Section 3.2 illustrate the application of the MIE_{λ} framework. In addition, the results can give several insights to design routing strategies and medium access policies to maximize the MIE_{λ} of the network. For instance, the results show that, in autonomous networks without SIR information, the best routing policy so as to maximize the network efficiency must be based on the closest-neighbour strategy. In addition, the existence of optimal operation points indicates that cognitive decisions such as adaptive transmission rates/ranges and frequency splitting based on the relative positions of the neighbours can improve the network performance.

In Section 3.3, the impact of using location information to improve the system performance in ad hoc networks is addressed in a different perspective. The performance of contention-based geographic forwarding strategies is assessed by means of system-level computational simulations. Preliminary results show that substantial gains are achieved by using local knowledge of network topology. Specifically, when compared to the totally random approach, the utilization of location information through the chain of relay nodes increases the packet delivery success ratio. Additionally, the length of trajectories is smaller when location awareness is used to perform localized routing decisions.

Using these preliminary results as a guideline and applying the MIE_{λ} framework as the analytical tool, the forthcoming investigations can be separated in two main fronts:

- 1) Extension of the evaluation scenarios to contemplate more realistic network deployments;
- 2) Design of macro policies (reflected in local decisions) where the location awareness has a fundamental role.

4 Conclusions

The applications of location awareness are multiple, including providing users with location information, developing novel location-aware applications and services, enhancing user's experience... Besides these direct applications, location-awareness can also be applied within the wireless networks themselves for the design and development of enhanced strategies and algorithms in order to improve network capacity and efficiency. Due to its unmatched accuracy, good performance on multipath and NLOS, low complexity and low power consumption, UWB is a good candidate to provide localization in indoor environments. Both cellular access networks and wireless ad-hoc networks can take advantage of location information provided by UWB.

Concerning cellular networks, the integration of positioning systems within the mobile operator's networks for localization of emergency calls encouraged the research on the possible applications of location-awareness. Several Radio Resource Management procedures can potentially be enhanced through the use of location information, such as handover management, admission control, resource allocation, load control and balancing... In fact, the design of predictive resource reservation algorithms for mobility management has been subject of extensive research, and multiple proposals of location-aware resource reservation schemes can be found in the literature. In this deliverable, an adaptive resource allocation algorithm for the Intersystem-handover (IS-HO) is investigated. The exploitation of location information for mobility management had already been proposed in e.g. 3GPP, where the OTDOA (Observed Time Difference of Arrival) positioning method is deployed to get the location information. In this deliverable, a seven-cell mobility model is deployed to realize the equilibrium character of a cluster. The aim of the research of adaptive resource allocation algorithms for IS-HO is to reduce the CDP (Call Dropping Probability) and CBP (Call Blocking Probability) under the constraint of a certain cell capacity.

Another relevant topic at the present time is the design of resource planning and allocation strategies aiming to minimize the co-channel interference in OFDM systems with frequency reuse of 1, which is being studied within the standardization processes of IEEE 802.16m and 3GPP LTE E-UTRA. Taking advantage of location awareness, dynamic interference coordination strategies could be developed. Our efforts in the following period will focus on the research and evaluation of location-aware resource allocation and scheduling schemes aiming to maximize the efficiency in an OFDMA-based cellular system.

In chapter 3, the utilization of MIE_n framework to assess the performance of autonomous network scenarios is illustrated. When considering distributed scenarios with limited or no SIR information, the results show that the best routing policy so as to maximize the network efficiency must be based on the closest-neighbour strategy. Furthermore, the existence of optimal operation points indicates that cognitive decisions such as adaptive transmission rates/ranges and frequency splitting based on the relative positions of the neighbours can improve the network performance. Additionally, the performance of contention-based geographic forwarding strategies is assessed by means of system-level simulations. Preliminary results show that substantial gains are achieved by using local knowledge of network topology. When compared to the totally random approach, the auction-based algorithm exploiting location information through the chain of relays increases the packet delivery success ratio. Moreover, the length of trajectories is smaller when location awareness is used to perform localized routing decisions.

References

- [1] Zeisberg, S., Schreiber, V.: "EUWB - Coexisting Short Range Radio by Advanced Ultra-Wideband RadioTechnology", ICT Mobile and Wireless Communications Summit, Stockholm, June 2008, accepted for publication
- [2] URL of EUWB consortium: <http://www.euwb.eu>
- [3] S. Naghian, "Hybrid Predictive Handover in Mobile Networks", Proc. 58th IEEE Vehicular Technology Conference (VTC 2003-Fall), October, 6 - 9 2003.
- [4] W. Teerapabkajornet, P. Krishnamurthy, "Comparison of Performance of Location-Aware and Traditional Handover-Decision Algorithms in CDPD Networks," Proc. IEEE VTC54th, 2001, vol.1, p.p. 212-216
- [5] W. Teerapabkajornet, P. Krishnamurthy, "Throughput Consideration for Location-Aware Handover in Mobile Data Networks," Proc. IEEE PIMRC13th, 2002, vol. 5, p.p. 2223-2227
- [6] M. H. Chiu, M. A. Bassiouni, "Predictive Schemes for Handover Prioritization in Cellular Networks Based on Mobile Positioning", IEEE Journal on Selected Areas in Communications, Vol 18, Issue 3, pp: 510-522, March 2000
- [7] M. Wu, W.E. Wong, and J.J. Li, "Performance evaluation of predictive handoff scheme with channel borrowing," Proc. 2003 IEEE International Performance, Computing, and Communications Conference, April 2003.
- [8] J. Sánchez-González, J. Pérez-Romero, O. Sallent "A Location-Aware Resource Reservation Algorithm with User Class Differentiation in WCDMA", IEEE VTC 2006, p. 1-5
- [9] Z. Xu, Z. Ye, S.V. Kirshnamurthy, S.K. Tripathi, M. Molle, A new adaptive channel reservation scheme for handoff calls in wireless cellular networks, LNCS, vol. 2345, pp. 672–684, 2002
- [10] Z. Ye, L.K. Law, S.V. Krishnamurthy, Z. Xu, S. Dhirakaosal, S.K. Tripathi, M. Molle, "Predictive channel reservation for handoff prioritization in wireless cellular networks" Computer Networks 51(3): 798-822 (2007)
- [11] J. Ye, J. Hou, S. Papavassiliou, "A Comprehensive Resource Management Framework for Next Generation Wireless Networks," IEEE Transactions on Mobile Computing, vol. 1, no. 4, pp. 249-264, Oct.-Dec. 2002
- [12] L.L. Lu, J.L.C. Wu, and H.H. Liu, "Mobility-aided adaptive resource reservation schemes in wireless multimedia networks," Computers and Electrical Engineering, vol.32, no.1–3, pp.102–117, April 2006.
- [13] K.L. Dias, D.F.H. Sadok, S.F.L. Fernandes, J. Kelner, "Approaches to Resource Reservation for Migrating Real-Time Sessions in Future Mobile Wireless Networks", Journal of Wireless Networks, Springer, 2008.
- [14] W.-S. Soh and H. S. Kim, "Dynamic guard bandwidth scheme for wireless broadband networks", in Proc. IEEE INFOCOM'01, Anchorage, Alaska, USA, Apr. 2001, pp. 572–581.
- [15] W.-S. Soh and H. S. Kim, "Dynamic Bandwidth Reservation in Cellular Networks using Road Topology based Mobility Predictions", Proc. of IEEE INFOCOM 2004, vol. 4, March 2004, pp. 2766- 2777.

- [16] I. Priggouris, E. Zervas, and S. Hadjiefthymiades, "Location Based Network Resource Management", Handbook of Research on Mobile Multimedia (Ed. Ismail Khalil Ibrahim), Idea Group Reference, May, 2006.
- [17] L. Du, J. Bigam and L. Cuthbert, "Towards intelligent geographic load balancing for mobile cellular networks", IEEE Transactions on Systems, Man and Cybernetics, Part C, vol. 33, no. 4, pp. 480-491, November 2003.
- [18] H. Abu-Ghazaleh, A.S. Alfa, "Mobility Prediction and Spatial-Temporal Traffic Estimation in Wireless Networks", Vehicular Technology Conference, 2008. VTC Spring 2008. IEEE , pp.2203-2207, 11-14 May 2008
- [19] S. Wu, T.W.S. Chow, K.T. Ng, "Using Cellular Probabilistic Self-Organizing Map in Borrowing Channel Assignment for Patterned Traffic Load", Neural Processing Letters Vol. 23 Issue 1, pp. 71-88, February 2006
- [20] 3GPP TS 25.305: "User Equipment (UE) positioning in Universal Terrestrial Radio Access Network (UTRAN)".
- [21] Philip, V., Stephen, S.: "On the Handoff Arrival Process in Cellular Communications", Wireless Networks 7, 147-157, 2001
- [22] Y. Xiang and J. Luo, "Inter-cell interference mitigation through flexible resource reuse in OFDMA based communication networks", in Proc. European Wireless 2007, pp. 1-7, April 2007.
- [23] IEEE Std 802.16e-2005 and IEEE Std 802.16-2004/Cor 1-2005, "IEEE Standard for Local and metropolitan area networks-Part 16: Air Interface for Fixed and Mobile Broadband Wireless Access Systems", Dec. 7, 2005.
- [24] "Mobile WiMAX-Part I: A Technical Overview and Performance Evaluation", WiMAX Forum White paper, June 2006.
- [25] H. Jia, Z. Zhang, G. Yu, P. Cheng, and S. Li, "On the performance of IEEE 802.16 OFDMA system under different frequency reuse and subcarrier permutation patterns", IEEE International Conference on Communications 2007 (ICC'07), pp. 5720-5725.
- [26] Y. Zhou and N. Zein, "Simulation study of fractional frequency reuse for mobile WiMAX", IEEE Vehicular Technology Conference 2008 (VTC Spring 2008), pp. 2592-2595.
- [27] IEEE C802.16m-08/782, "Fractional Frequency Reuse in Uplink" J.Y. Han, H.G. Cho (LG Electronics), July 2008
- [28] IEEE C802.16m-09/0059, "Self-optimizing FFR" J. Chou, S. Talwar, C. Chen (Intel), January 2009
- [29] IEEE C802.16m-09/0149, "A clustering method with virtual cell and low complexity coordination scheme for dynamic inter-cell interference mitigation" P. Wen, M. You (Alcatel Shanghai Bell), January 2009
- [30] IEEE C802.16m-09/0933, "Interference Mitigation using Flexible Fractional Frequency Reuse" Z. Tao, P. Orlik, R. Annavajjala, J. Zhang, T. Kuze (Mitsubishi), April 2009
- [31] IEEE 802.20-05/68r1, "MBFDD and MBTDD wideband mode", J. Tomcik (Qualcomm) Jan. 2006.

- [32] 3GPP, R1-050738 “Interference mitigation – Considerations and Results on Frequency Reuse”. Siemens, TSG-RAN WG1 #42 Meeting, London, UK, August 29–September 2, 2005
- [33] 3GPP, R1-050764 “Inter-cell Interference Handling for E-UTRA”. Ericsson, TSG-RAN WG1 #42 Meeting, London, UK, August 29–September 2, 2005
- [34] 3GPP, R1-050507 “Soft Frequency Reuse Scheme for UTRAN LTE”. Huawei, TSG-RAN WG1 #41 Meeting, Athens, Greece, 9 – 13 May, 2005
- [35] 3GPP, R1-060291 “OFDMA Downlink inter-cell interference mitigation”. Nokia, TSG-RAN WG1 #44 Meeting, Denver, Colorado, February 13 - 17, 2006
- [36] 3GPP, R1-050833 “Interference mitigation in evolved UTRA/UTRAN”. LG Electronics, TSG-RAN WG1 #42 Meeting, London, UK, August 29–September 2, 2005
- [37] 3GPP, R1-050407 “Interference Coordination in new OFDM DL air interface”. Alcatel, 3GPP TSG-RAN WG1#41 Meeting, Athens, Greece, 9 – 13 May, 2005
- [38] 3GPP, R1-050695 “Interference Coordination for Evolved UTRA Uplink Access”. Alcatel, 3GPP TSG-RAN WG1#42 Meeting, London, UK, August 29–September 2, 2005
- [39] K. T. Kim and S. K. Oh, "A universal frequency reuse system in a mobile cellular environment", in Proc. IEEE VTC2007-Spring, pp. 2855-2859, April 2007.
- [40] Z. J. Haas, J. H. Winters and D. S. Johnson, “Simulation Results of the Capacity of Cellular Systems”, IEEE Transactions on Vehicular Technology, Vol. 46, No. 4, November 1997
- [41] S. Weber, X. Yang, J. G. Andrews, and G. de Veciana, “Transmission capacity of wireless ad hoc networks with outage constraints,” IEEE Transactions on Information Theory, vol. 51, 2005.
- [42] A. Baddeley, Spatial Point Processes and their Applications: *Spatial Point Processes and their Applications*. Springer Berlin, 2007.
- [43] M. Haenggi, “On distances in uniformly random networks,” IEEE Transactions on Information Theory, vol. 51, 2005.
- [44] F. Ye and B. Sikdar, “Evaluation of spatial reuse in wireless multiple access networks,” in IEEE VTC, 2004.
- [45] J.-W. Lee, A. Tang, J. Huang, M. Chiang, and A. R. Calderbank, “Reverse-engineering MAC: Anon-cooperative game model,” IEEE Journal on Selected Areas in Communications, vol. 25, no. 6, pp. 1135–1147, August 2007.
- [46] V. Rodriguez and F. Jondral, “Simple, adaptively-prioritised, spatially-reusable medium access control through the dutch auction, with decentralised implementation for synchronised terminals,” in 14th IEEE Symposium on Communications and Vehicular Technology in the Benelux, 2007, 15 November 2007, pp. 1–3.
- [47] S. Biswas and Y. Narahari, “Iterative Dutch combinatorial auctions,” Annals of Mathematics and Artificial Intelligence, vol. 44, no. 3, pp. 185–205, 2005.
- [48] P. Mathys and P. Flajolet, “Q-ary collision resolution algorithms in random-access systems with free or blocked channel access,” IEEE Transactions on Information Theory, vol. 31, no. 2, pp. 217–243, March 1985.
- [49] C. H. M. de Lima and G. T. F. de Abreu, “Game-theoretical relay selection strategy for geographic routing in multi-hop WSNs,” in 5th Workshop on Positioning, Navigation and Communication 2008 (WPNC’08), Leibniz University of Hannover, Germany, March 27 2008.

- [50] C. H. M. de Lima and G. T. F. de Abreu, “Contention-based Geographic Forwarding Strategies for Position-centric Routing”, in 6th Workshop on Positioning, Navigation and Communication 2008 (WPNC’08), Leibniz University of Hannover, Germany, March 19 2008.
- [51] C. H. M. de Lima and G. T. F. de Abreu, “Analysis of Contention-based Relay Selection Mechanisms in Autonomous Multi-hop Networks”, in IEEE Information Theory Workshop on Networking and Information Theory (ITW’09), Volos, Greece, June 10-12, 2009.
- [52] V. Krishna, Auction Theory, 1st ed. Academic Press, March 2002.
- [53] C. H. M. de Lima and G. T. F. de Abreu, “Clusterization for robust geographic routing in wireless sensor networks,” in Wireless Communications & Networking Conference (WCNC), Las Vegas, Nevada, USA, 31 March – 3 April 2008.

Acknowledgement

The EUWB consortium would like to acknowledge the support of the European Commission partly funding the EUWB project under Grant Agreement FP7-ICT-215669 [1],[2].